

Lubricated 65 Series Rotary Vane Vacuum Pumps & Compressors

Operation & Maintenance Manual

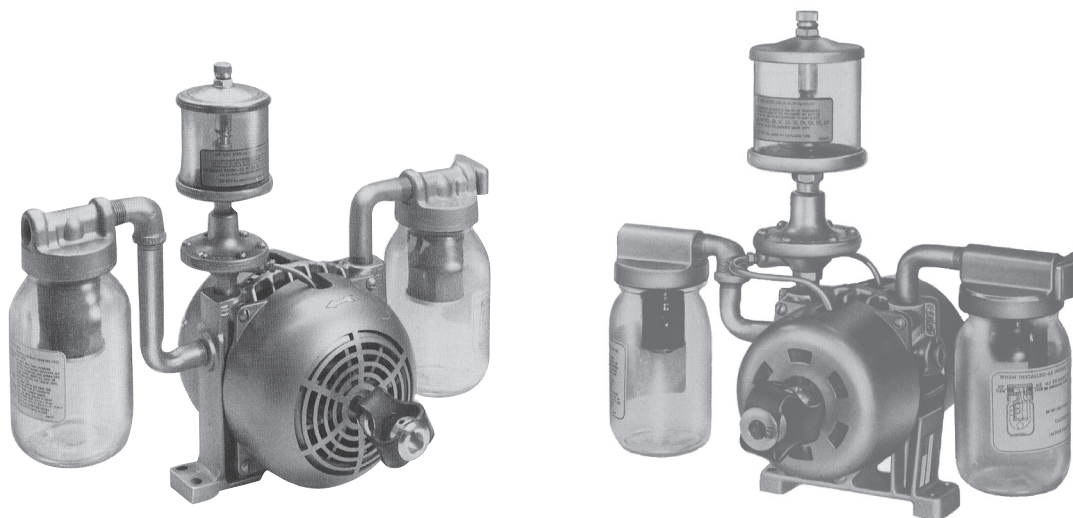

Lubricated 65 Series Rotary Vane Vacuum Pumps and Compressors Shown

GAST

A UNIT OF IDEX CORPORATION

www.gastmfg.com

Dear Customer:

Thank you for purchasing this Gast product. It is manufactured to the highest standards using quality materials. Please follow all recommended maintenance, operational, and safety instructions, and you will receive years of trouble-free service.



WARNING



PLEASE READ THIS MANUAL COMPLETELY BEFORE INSTALLING AND USING THIS PRODUCT. SAVE THIS MANUAL FOR FUTURE REFERENCE AND KEEP IN THE VICINITY OF THE PRODUCT.

TABLE OF CONTENTS

Product Use, Criteria, and Purpose	3
Mounting	4
Plumbing	4
Accessories	4
Motor Control	4
Electrical Connection	4
Operation	5
Start Up	5
Maintenance	6
Shutdown Procedures	7
Service Kit Installation	7
Parts and Ordering Information	9-13
Lubricator Assemblies	14
Warranty	15
Troubleshooting Chart	16

PRODUCT USE, CRITERIA, AND PURPOSE

- Operate at 32 °F to 104 °F (0 °C to 40 °C).
- Protect unit from dirt and moisture.
- Do not pump flammable or explosive gases or use in an atmosphere that contains such gases.
- Protect all surrounding items from exhaust air. This exhaust air can become very hot.
- Product is not a consumer product and is for commercial applications only.
- Corrosive gases and particulate material will damage unit. Water vapor, oil-based contaminants, or other liquids must be filtered out.
- Consult your Gast Distributor/Representative before using at high altitudes.
- Use Gast #AD220 or a detergent SAE#10 automotive engine oil for lubricating.

Your safety and the safety of others is extremely important.

We have provided many important safety messages in this manual and on your product. Always read and obey all safety messages.



This is the safety alert symbol. This symbol alerts you to hazards that can kill or hurt you and others. The safety alert symbol and the words “DANGER” and “WARNING” will precede all safety messages. These words mean:

DANGER

You will be killed or seriously injured if you don't follow instructions.

WARNING

You can be killed or seriously injured if you don't follow instructions.

All safety messages will identify the hazard, tell you how to reduce the chance of injury, and tell you what can happen if the safety instructions are not followed.

INSTALLATION

WARNING

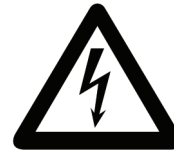

Electrical Shock Hazard

Disconnect electrical power at the circuit breaker or fuse box before installing this product.

Install this product where it will not come into contact with water or other liquids.

Install this product where it will be weather protected.

Electrically ground this product.

Failure to follow these instructions can result in death, fire, or electrical shock.

Correct installation is your responsibility.

Make sure you have the proper installation conditions and that installation clearances do not block airflow. Proper guards should be installed to prevent contact with moveable parts of this pump. Do not lift the unit by the fan shroud. Unit is to be lifted by means of eyebolts.

Blocking air flow over the product in any way can cause the product to overheat.**Mounting**

Mounting the product to a stable, rigid operating surface and using shock mounts will reduce noise and vibration.

Plumbing

To prevent air flow restriction, use pipe and fittings that are the same size or larger than the threaded ports of the pump. The ports are marked "IN" and "OUT". If the distance is great, use lines with a larger diameter than the connections. Give lines a uniform slope, place drain cock at low point, and avoid extra elbows. For ease of servicing, use a union or hose with clamps near the pump (a hose helps eliminate noise and vibration). If a vacuum/pressure supply tank is used, slope the line towards tank, provide a drain at the bottom, and place a check valve between the tank and pump so the pump will not run backwards when turned off.

Accessories

Intake and exhaust filters are external to the pump and will provide adequate filtration for most applications. Check filters periodically and replace when necessary. Consult your Gast Distributor/ Representative for additional filter recommendations.

Install relief valves and gauges at inlet or outlet or both, to monitor performance. Check valves may be required to prevent back streaming through the pump.

Motor Control

It is your responsibility to contact a qualified electrician and assure that the electrical installation is adequate and in conformance with all national and local codes and ordinances.

Determine the correct overload setting required to protect the motor (see motor starter manufacturer's recommendations). Select fuses, motor protective switches, or thermal protective switches to provide protection. Fuses act as short circuit protection for the motor, not as protection against overload. Incoming line fuses must be able to withstand the motor's starting current. Motor starters with thermal magnetic overload or circuit breakers protect motor from overload or reduced voltage conditions.

The wiring diagram supplied with the product provides required electrical information. Check that power source is correct to properly operate the dual-voltage motors.

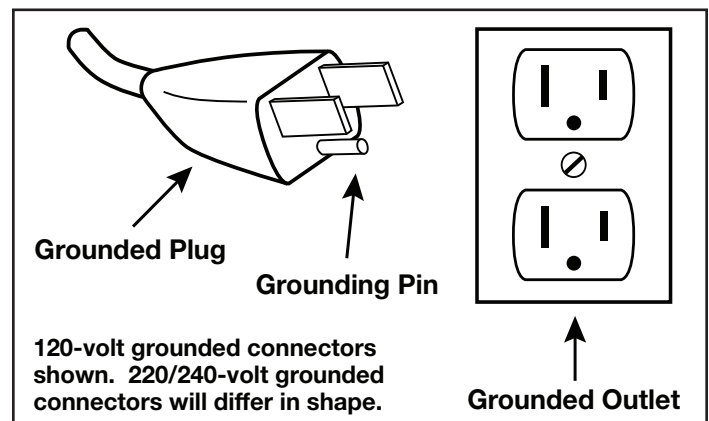
Electrical Connection**Model with a power supply cord:**

This product must be grounded. For either 120-volt or 220/240-volt circuits connect power supply cord grounding plug to a matching grounded outlet. Do not use an adapter. (See above diagram.)

In the event of an electrical short circuit, grounding reduces the risk of electric shock by providing an escape wire for the electric current. This product may be equipped with a power supply cord having a grounding wire with an appropriate grounding plug. The plug must be plugged into an outlet that is properly installed and grounded in accordance with all local codes and ordinances.

Check with a qualified electrician or serviceman if the grounding instructions are not completely understood, or if you are not sure whether the product is properly grounded. Do not modify the plug provided. If it will not fit the outlet, have the proper outlet installed by a qualified electrician.

Model that is permanently wired:

This product must be connected to a grounded, metallic, permanent wiring system, or an equipment grounding terminal or lead on the product.

Power supply wiring must conform to all required safety codes and be installed by a qualified person. Check that supply voltage agrees with that listed on product nameplate.

Extension cords:

Use only a 3-wire extension cord that has a 3-blade grounding plug. Connect extension cord plug to a matching 3-slot receptacle. Do not use an adapter. Make sure your extension cord is in good condition. Check that the gage wire of the extension cord is the correct size wire to carry the current this product will draw.

Minimum gage for extension cords

Amps	Volts	Length of cord in feet													
		120v	25	50	100	150	200	250	300	400	500				
	240v	50	100	200	300	400	500	600	800	1000					
0-2		18	18	18	16	16	14	14	12	12					
2-3		18	18	16	14	14	12	12	10	10					
3-4		18	18	16	14	12	12	10	10	8					
4-5		18	18	14	12	12	10	10	8	8					
5-6		18	16	14	12	10	10	8	8	8					
6-8		18	16	12	10	10	8	6	6	6					
8-10		18	14	12	10	8	8	6	6	4					
10-12		16	14	10	8	8	6	6	4	4					
12-14		16	12	10	8	6	6	6	4	2					
14-16		16	12	10	8	6	6	4	4	2					
16-18		14	12	8	8	6	4	4	2	2					
18-20		14	12	8	6	6	4	4	2	2					

OPERATION

WARNING





Injury Hazard

Install proper safety guards as needed. Pumps with glass jars need safety guards to protect against breaking glass.

Use only recommended air handling parts acceptable for pressure not less than 70 psi..

Keep fingers and objects away from openings and rotating parts.

When provided, motor terminal covers must be in place for safe operation.

Check that coupling guard and shroud are in place before operating.

Product surfaces may become hot during operation, allow product surfaces to cool before handling.

Do Not direct air stream at body. Air stream from product may contain solid or liquid material that can result in eye or skin damage, wear proper eye protection.

Do Not spray flammable or combustible liquid.

Wear hearing protection. Sound level from product may exceed 85 dBA.

Failure to follow these instructions can result in burns, eye injury or other serious injury.

It is your responsibility to operate this product at recommended pressures or vacuum duties and room ambient temperatures. Do not start against a vacuum or pressure load.

Start Up

If pump is extremely cold, let it warm up to room temperature before starting. If motor fails to start or slows down significantly under load, shut off and disconnect from power supply. Check that the voltage is correct for motor and that motor is turning in the proper direction. Turning in the wrong direction will drastically reduce vane life. Vane life will be drastically reduced if motor is not operating properly. Vanes can break or be damaged if motor/pump runs in the wrong direction.

MAINTENANCE

! WARNING



Electrical Shock Hazard

Disconnect electrical power supply cord before performing maintenance on this product.

If product is hard wired into system, disconnect electrical power at the circuit breaker or fuse box before performing maintenance on this product.

Failure to follow these instructions can result in death, fire, or electrical shock.

! WARNING



Injury Hazard

Wear eye protection when flushing this product.

Air stream from product may contain solid or liquid material that can result in eye or skin damage.

Flush this product in a well ventilated area.

Do Not use kerosene or other combustible solvents to flush this product.

Failure to follow these instructions can result in eye injury or other serious injury.

It is your responsibility to:

- **Regularly inspect and make necessary repairs to product in order to maintain proper operation.**
- **Make sure that pressure is released from product before starting maintenance.**

Check intake and exhaust filters after first 500 hours of operation. Clean filters and determine how frequently filters should be checked during future operation. **This one procedure will help to assure the product's performance and service life.**

Clean filters when necessary by removing and washing in a solvent or soap and water. After cleaning, dry with compressed air to make sure all moisture is removed before replacing filters.

Flushing

Flushing this product to remove excessive dirt, foreign particles, moisture, or oil that occurs in the operating environment will help to maintain proper vane performance. If your pump is not getting the vacuum or pressure level expected, flushing is required. Vanes will stick when dirty and may cause pump to be noisy or inefficient.

Use only Gast recommended Flushing Solvent or other non-petroleum based flushing solvent. Do not use kerosene or ANY other combustible solvent to flush product.

1. Disconnect electrical power supply.
2. Release all pressure and vacuum from pump.
3. Remove all accessories at the inlet and exhaust ports.
4. Remove filter.
5. Start product. Place towel over exhaust port to clean up solvent. If using liquid solvent, pour several tablespoons directly into inlet port. If using Gast recommended Flushing Solvent, spray solvent for 5-10 seconds into inlet port.
6. Block the inlet port and draw a deep vacuum for 15-20 seconds. Release the vacuum.
7. Listen for changes in the sound of the motor. If motor sounds smooth, go to next step. If motor does not sound like it is running smoothly, repeat steps 5 and 6 until you can hear a difference in the operating sound of the pump.
8. Start the pump and let it run for 1 minute, then turn pump off.
9. Replace all accessories at the inlet and exhaust ports.
10. Replace filter before resuming operation.

Check that all external accessories such as relief valves and gauges are attached to cover and are not damaged before re-operating product.

SHUTDOWN PROCEDURES

It is your responsibility to follow proper shutdown procedures to prevent product damage.

Proper shutdown procedures must be followed to prevent pump damage. Failure to do so may result in premature pump failure. The Gast Manufacturing Lubricated Vacuum Pumps and Compressors are constructed of ferrous metals or aluminum which are subject to rust and corrosion when pumping condensable vapors such as water. Follow the steps below to assure correct storage and shutdown between operating periods.

1. Disconnect plumbing.
2. Operate product for at least 5 minutes without plumbing.
3. Cover inlet port (vacuum side) and run pump for 1-3 minutes. Shut the pump down under vacuum.
4. This unit requires lubrication. Refill oil reservoir to proper level before storage.
5. Be sure to plug open ports so dirt and other contaminants do not enter the unit. It is now ready for shutdown.

SERVICE KIT INSTALLATION

WARNING



Electrical Shock Hazard

Disconnect electrical power supply cord before installing Service Kit.

If product is hard wired into system, disconnect electrical power at the circuit breaker or fuse box before installing Service Kit.

Vent all air lines to release pressure or vacuum.

Failure to follow these instructions can result in death, fire, or electrical shock.

Gast will NOT guarantee field-rebuilt product performance. For performance guarantee, the product must be returned to a Gast Authorized Service Facility.

Service Kit contents vary. Most contain vanes, gaskets oiler wick, and filter elements.

Pump Disassembly:

1. Remove dead end shroud, fan, and fan spacer.
2. Use a wheel puller to remove dead end plate and bearing from unit body; note direction of vane's bevel edge. Do not damage dowel pins between end plate and body.
3. Save bearing spacer on shaft's dead end for re-assembly.
4. Remove snap ring from end plate.
5. Save snap ring, Belleville springs, and washer for re-assembly.
6. Remove bearing from dead-end plate.
7. Check exposed surfaces of rotor, body, and end plate for scoring. If no scoring is found, perform Minor Rebuild to replace only vanes and dead end bearing. If severe damage is found, perform Major Rebuild.

Minor Rebuild:

Install new vanes supplied with kit. Be careful to face vane bevels in proper direction (as noted in step 2).

9. Place end plate over shaft with dowel pins aligned.
10. Place bearing spacer on dead end of shaft.
11. Place new bearing in its bore in dead end plate.
Be careful to press only on inner bearing race.
12. Install and tighten unit body bolts.
13. Install Belleville springs with washer between them and snap ring.

Major Rebuild:

8. Remove drive end cap.
9. Use a wheel puller to remove drive end plate and bearing from body. Do not remove or damage dowel pins in body.
10. Save bearing spacer and endplate gasket for re-assembly.
11. Place one of new bearings in its seat in drive-end plate, then place one of shoulder rings on drive-end of shaft.
12. Using an arbor press, press bearing onto shaft.
Be careful to press only on inner bearing race.
13. Tighten unit body bolts.
14. Install new vanes supplied with kit. Be careful to face vane bevels in proper direction (see step 2).
15. Perform steps #9-11 from Minor Rebuild.
16. Install Belleville springs with washer between them and snap ring.

17. Install and tighten unit body bolts.
18. Apply a thread-lock adhesive.
19. Start drive end cap into its thread in drive end plate, but do not tighten it.
20. Place a dial indicator against dead-end of shaft to measure axial movement.
21. Tighten drive end cap until indicator shows .002" to .003" of shaft movement against Belleville springs.
22. Replace filter elements.
23. Verify unit rotates freely by hand before reconnecting power.
24. Before putting unit into service, ensure that any external accessories have not been damaged.
25. Reconnect power.
26. Check for proper rotation if unit is three-phase motor.

If unit fails to produce proper vacuum or pressure, or is excessively noisy, turn off and return unit to an Authorized Service Facility.

Disposal: (Please note current regulations)

Parts of the rotary vane pumps and compressors, shafts, iron or aluminum castings, plastic or glass parts, or bearings, may be recycled as scrap materials.



1065 SERIES EXPLODED PRODUCT VIEW, PARTS, AND ORDERING INFORMATION

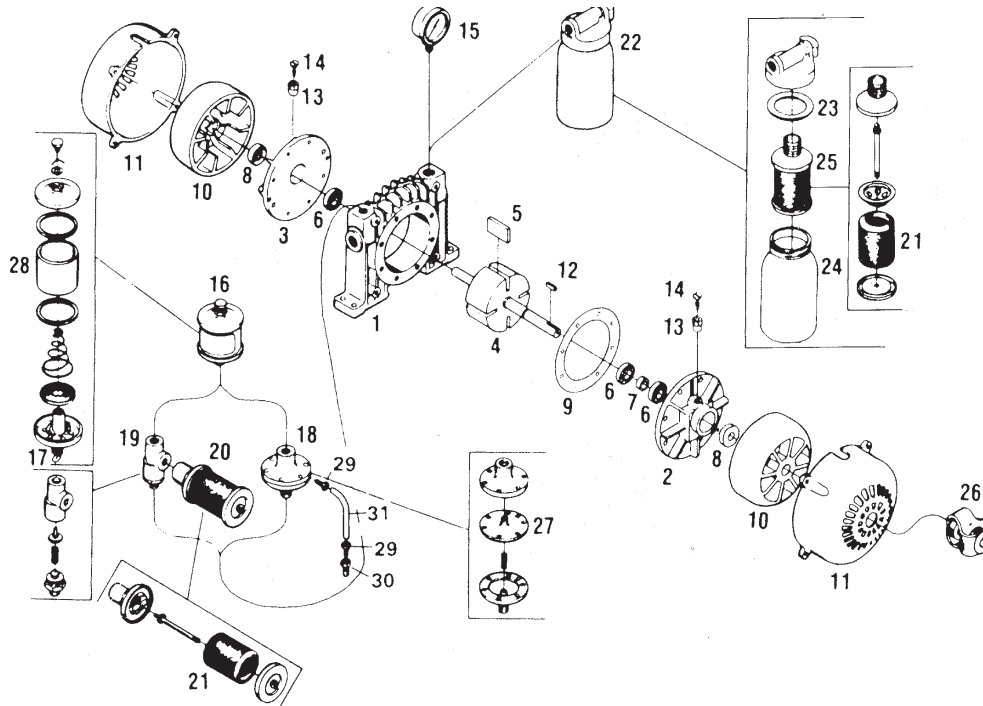

REF	DESCRIPTION	QTY	1065-V2A	1065-V3B	1065-P18
1	Body	1	AC860	AC860	AC860B
2	Drive end plate	1	D1322	D1322	D1322D
3	Dead end plate	1	D1322A	D1322A	D1322E
4	Rotor and shaft assembly	1	D334H	D334H	D334H
5 Δ	Vane	4	D335K	D335K	D335K
6 Δ	Bearings	3	D327	D327	D327
7 Δ	Bearing spacer	1	D316	D316	D316
8 Δ	Shaft seal	2	AA150	AA150	AA150
9 Δ	Body soacer	1	AH567	AH567	AH567
10	Cooling fan	2	AC326A	AC326A	AC326A
	Retainer ring**	2	AC446	AC446	AC446
11	Fan guard	2	AC102B	AC102B	AC102B
12 Δ	Coupling key	1	AB136D	AB136D	AB136D
13	Oiler body	2			AG468
14	Oiler cap	2			AA11B
15	Pressure gauge	1			AA644B
16	Oil reservoir assembly	1	AA960-2	AA960-2	AA960-2
17 Δ	Feed wick	1	AA273-1	AA273-1	AA273-1
18	Vacuum lubricator assembly	1	V40C	V40C	
19	Pressure lubricator assembly	1			AC380C
20	Intake filter assembly	1	AA800C	AA800C	AC432
21 Δ	Cartridge	2	AC393	AC393	AC393
22	Exhaust muffler and oil trap	1	AA800D	AA800D	
23	Cover gasket	1	AA405	AA405	
24	Glass jar	1	AA401	AA401	
25	Muffler element assembly	1	AC434-1	AC434-1	
26	Coupling assembly	1	AE542A	AE542A	AE542A
27	Diaphragm	1	V33	V33	
28	Oil cylinder	1	AA967A	AA967A	
29	Fitting	4	V31	V31	
30	Connector	2	V32A	V32A	
31	Tube	2	AF339	AF339	
***	Service kit	1	K297	K297	K297

*** Item not shown.

** Retainer ring must be ordered with cooling fan.

Δ Denotes parts included in the Service Kit.

Parts listed are for stock models. For specific OEM models, please consult the factory.

When corresponding or ordering parts, please give complete model and serial numbers.

2065/2565 SERIES EXPLODED PRODUCT VIEW, PARTS, AND ORDERING INFORMATION

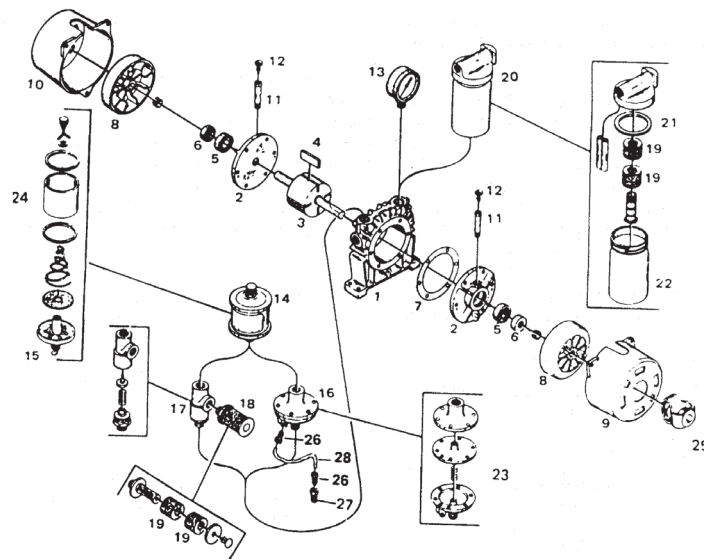

REF	DESCRIPTION	QTY	2065-V2A	2065-P8	2565-V2A	2565-P19
1	Body	1	AC101E	AC101E	AC101F	AC101F
2	Drive end plate	1	AA851	AA852	AA846	AA847
3	Dead end plate	1	AA851	AA853	AA846	AA848
4	Rotor assembly	1	AC843A	AC843A	AC840	AC840
5 Δ	Vane	4	AA8D	AA8D	AA750G	AA750G
6 Δ	Drive end bearing	1	AA735	AA735	AA735	AA735
7 Δ	Dead end bearing	1	AA755D	AA755D	AA755D	AA755D
8 Δ	Drive end shaft seal	1	AC848	AC848	AC848	AC848
9 Δ	Dead end shaft seal	1	AC849	AC849	AC849	AC849
10	Body spacer	1	AH567	AH567	AH567	AH567
11	Cooling fan	1	AC326C	AC326C	AC326C	AC326C
	Retainer ring**	1	AC448	AC448	AC448	AC448
12	Cooling fan	1	AC326B	AC326B	AC326B	AC326B
	Retainer ring**	1	AC447	AC447	AC447	AC447
13	Coupling key	1	AB136D	AB136D	AB136D	AB136D
14	Fan guard	2	AC102B	AC102B	AC102B	AC102B
15	Drive end cap	1	AA856	AA856	AA856	AA856
16	Dead end cap	1	AG466	AG466	AG466	AG466
17 Δ	O-ring	1	AC808	AC808	AC808	AC808
18	End cap gasket	2	AG467	AG467	AG467	AG467
19	Oiler body	2		AA10		AA10
20	Oiler cap	2		AA11B		AA11B
21	Pressure gauge	1		AA644B		AA644B
22	Coupling assembly	1	AE543B	AE543B	AE543B	AE543B
23 Δ	Oil reservoir assembly	1	AA960-1	AA960-1	AA960-1	AA960-1
24 Δ	Feed wick	1	AA973-1	AA973-1	AA973-1	AA973-1
25	Vacuum lub assembly	1	V40C		V40C	
26	Pressure lub assembly	1		AA95A		AA95A
27 Δ	Intake filter assembly	1	AA900D	AC435	AA900D	AC435
28 Δ	Cartridge	2	AC393	AC393	AC393	AC393
29 Δ	Exhaust muffler and oil trap	1	AA900E		AA900E	
30	Cover gasket	1	AA405		AA405	
31	Glass jar	1	AA401		AA401	
32 Δ	Muffler element assembly	1	AC436		AC436	
33	Diaphragm	1	V33		V33	
34	Oil cylinder	1	AA967A		AA967A	
35	Fitting	4	V31		V31	
36	Connector	2	V32A		V32A	
37	Tube	2	AF339A		AF339A	
***	Service kit	1	K295	K295	K296	K296

*** Item not shown.

** Retainer ring must be ordered with cooling fan.

Δ Denotes parts included in the Service Kit.

Parts listed are for stock models. For specific OEM models, please consult the factory.

When corresponding or ordering parts, please give complete model and serial numbers.

0765 SERIES EXPLODED PRODUCT VIEW, PARTS, AND ORDERING INFORMATION

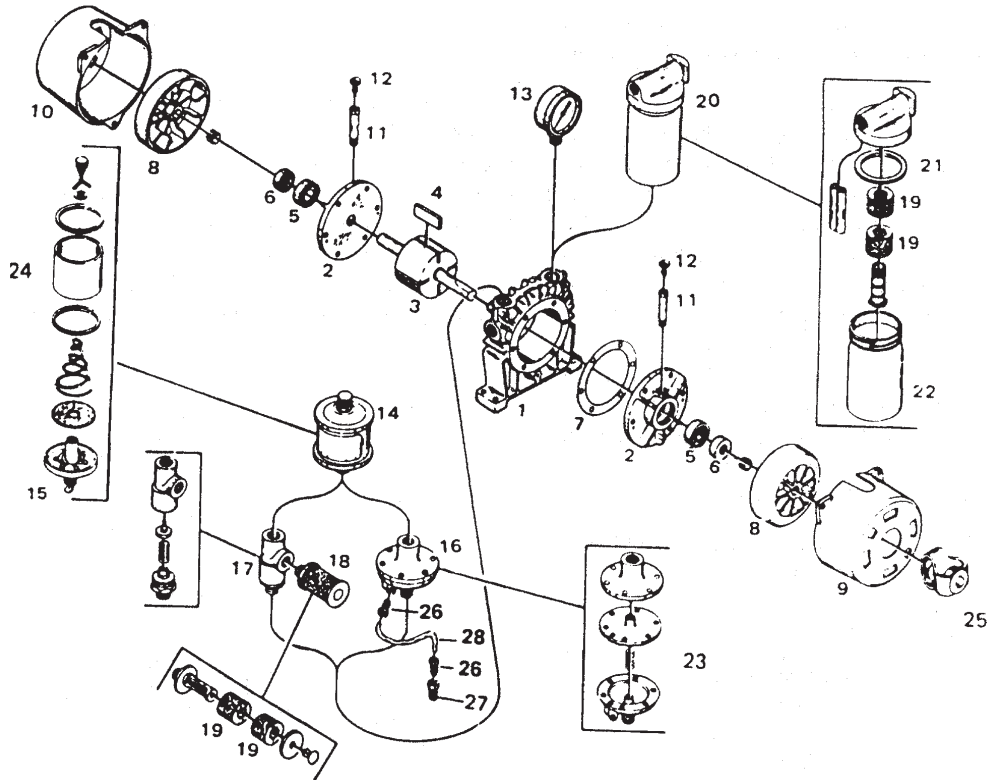

REF	DESCRIPTION	QTY	0765-V6A	0765-V7C
1	Body	1	AC681A	AC681A
2	End plate	2	AA502	AA502
3	Rotor and shaft assembly	1	AA508A	AA508A
4 Δ	Vane	4	AA510E	AA510E
5 Δ	Bearing	2	AA37	AA37
6 Δ	Shaft seal	2	AA466B	AA466B
7 Δ	Body spacer	1	B330	B330
8	Cooling fan	2	B340C	B340C
9	Fan guard	1	AC684A	AC684A
10	Fan guard	1	AC684A	AC684A
11	Oiler body	0		
12	Oiler cap	0		
13	Pressure gauge	0		
14	Oil reservoir assembly	1	AA960-2	AA960-2
15 Δ	Feed wick	1	AA273-1	AA273-1
16	Vacuum lubricator assembly	1	V40C	V40C
17	Pressure lubricator assembly	0		
18	Intake filter assembly	1	B343B	B343B
19 Δ	Filter felt	4	B344A	B344A
20	Exhaust muffler and oil trap	1	V525	V525
21 Δ	Cover gasket	1	B62A	B62A
22	Glass jar	1	AA125	AA125
23	Diaphragm	1	V33	V33
24	Oil cylinder	1	AA967A	AA967A
25	Coupling	1	AE541C	AE541C
26	Fitting	4	V31	V31
27	Connector	2	V32A	V32A
28	Tube	2	V57	V57
***	Service kit	1	K235	K235

*** Item not shown.

** Retainer ring must be ordered with cooling fan.

Δ Denotes parts included in the Service Kit.

Parts listed are for stock models. For specific OEM models, please consult the factory.

When corresponding or ordering parts, please give complete model and serial numbers.

LUBRICATOR ASSEMBLIES

The following information on oil reservoirs and lubricators has been written to give an understanding of various assemblies used on Gast pumps and compressors.

Lighter duty pumps use wicks to regulate oil flow, while heavy-duty oilers are available for those applications where large units are operating continuously under harsh conditions.

Oil Reservoir AA960 Series

AA960 oil reservoir type has a wick that regulates oil flow and a bleed hole that equalizes pressure between bearing cavity and air on top of oil in reservoir. V40C, below reservoir, is a valve that is vacuum actuated (it opens at about 850 mbar) and stops oil flow when unit is turned off. It does not regulate oil flow in any way.

*Reservoir must be sealed tightly at top filler hole so that atmospheric air does not leak in and increase oil flow. Wick in reservoir regulates oil flow. A single wick gives highest flow rate and a double or triple wick, progressively less. If there are no leaks in lubrication system, oil flows by gravity to unit bearings and into pumping chamber to lubricate vanes as well.

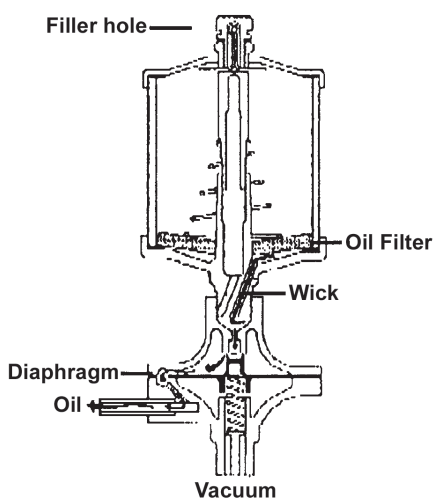

Pressure Lubricator Assembly AA95A/AD730

A380C pressure oiler using an AA960 type reservoir, acts as a valve to stop oil flow when unit is off. Inside a spring-loaded poppet opens due to airflow and pulls a tapered pin from oil hole and allows lubrication to start. When unit is turned off, tapered pin pops back into place and oil flow stops. AA95A and AD730 function the same way.

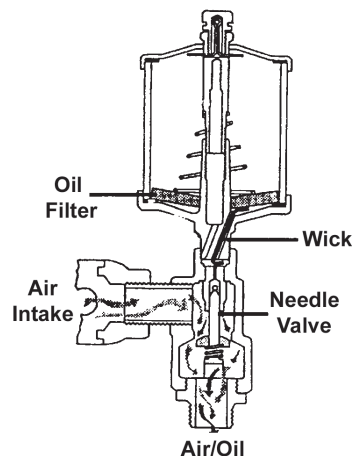

Motorized Assembly AD190 Series

Heavy-duty AD190 oiler uses a large AD185 1-liter reservoir and an electrically driven metering pump that dispenses oil to two tubes leading to bearings. Different discs are available for unit to dispense 1, 2, 3, or 4 drops per minute. Different units are used for vacuum and pressure. To change a vacuum lubricator into a pressure type, change springs loading metering disc against housing. On pressure applications, tubes carrying oil to bearings will be pressurized by air inside unit to about half operating pressure. If pressure is excessive, there will be oil leakage.

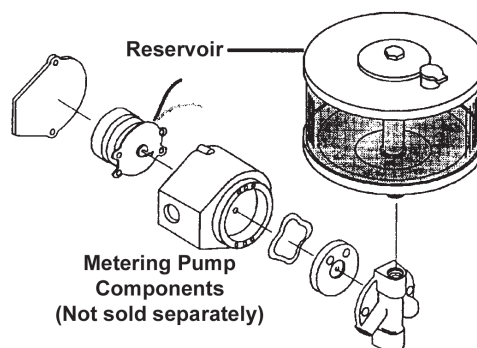

WARRANTY POLICY

Gast finished products, when properly installed and operated under normal conditions of use, are warranted by Gast to be free from defects in material and workmanship for a period of twelve (12) months from the date of purchase from Gast or an authorized Gast Representative or Distributor. In order to obtain performance under this warranty, the buyer must promptly (in no event later than thirty (30) days after discovery of the defect) give written notice of the defect to Gast Manufacturing Incorporated, PO Box 97, Benton Harbor Michigan USA 49023-0097 or an authorized Service Center (unless specifically agreed upon in writing signed by both parties or specified in writing as part of a Gast OEM Quotation). Buyer is responsible for freight charges both to and from Gast in all cases.

This warranty does not apply to electric motors, electrical controls, and gasoline engines not supplied by Gast. Gast's warranties also do not extend to any goods or parts which have been subjected to misuse, lack of maintenance, neglect, damage by accident or transit damage.

THIS EXPRESS WARRANTY EXCLUDES ALL OTHER WARRANTIES OR REPRESENTATIONS EXPRESSED OR IMPLIED BY ANY LITERATURE, DATA, OR PERSON. GAST'S MAXIMUM LIABILITY UNDER THIS EXCLUSIVE REMEDY SHALL NEVER EXCEED THE COST OF THE SUBJECT PRODUCT AND GAST RESERVES THE RIGHT, AT ITS SOLE DISCRETION, TO REFUND THE PURCHASE PRICE IN LIEU OF REPAIR OR REPLACEMENT.

GAST WILL NOT BE RESPONSIBLE OR LIABLE FOR INDIRECT OR CONSEQUENTIAL DAMAGES OF ANY KIND, however arising, including but not limited to those for use of any products, loss of time, inconvenience, lost profit, labor charges, or other incidental or consequential damages with respect to persons, business, or property, whether as a result of breach of warranty, negligence or otherwise. Notwithstanding any other provision of this warranty, BUYER'S REMEDY AGAINST GAST FOR GOODS SUPPLIED OR FOR NON-DELIVERED GOODS OR FAILURE TO FURNISH GOODS, WHETHER OR NOT BASED ON NEGLIGENCE, STRICT LIABILITY OR BREACH OF EXPRESS OR IMPLIED WARRANTY IS LIMITED SOLELY, AT GAST'S OPTION, TO REPLACEMENT OF OR CURE OF SUCH NONCONFORMING OR NON-DELIVERED GOODS OR RETURN OF THE PURCHASE PRICE FOR SUCH GOODS AND IN NO EVENTS SHALL EXCEED THE PRICE OR CHARGE FOR SUCH GOODS. GAST EXPRESSLY DISCLAIMS ANY WARRANTY OF MERCHANTABILITY OR FITNESS FOR A PARTICULAR USE OR PURPOSE WITH RESPECT TO THE GOODS SOLD. THERE ARE NO WARRANTIES WHICH EXTEND BEYOND THE DESCRIPTIONS SET FORTH IN THIS WARRANTY, notwithstanding any knowledge of Gast regarding the use or uses intended to be made of goods, proposed changes or additions to goods, or any assistance or suggestions that may have been made by Gast personnel.

Unauthorized extensions of warranties by the customer shall remain the customer's responsibility.

CUSTOMER IS RESPONSIBLE FOR DETERMINING THE SUITABILITY OF GAST PRODUCTS FOR CUSTOMER'S USE OR RESALE, OR FOR INCORPORATING THEM INTO OBJECTS OR APPLICATIONS WHICH CUSTOMER DESIGNS, ASSEMBLES, CONSTRUCTS OR MANUFACTURES.

This warranty can be modified only by authorized Gast personnel by signing a specific, written description of any modifications.

TROUBLESHOOTING CHART

Low		High		Pump Overheat	Motor Overload	Reason and remedy for problem.
Vacuum	Pressure	Vacuum	Pressure			
x	x	At pump		x	x	Filter dirty. Clean or replace.
	x		At pump	x	x	Muffler dirty. Clean or replace.
x		At pump		x	x	Vacuum line collapsed. Repair or replace.
x			x	x	x	Relief valve set too high. Inspect and adjust.
x	x					Relief valve set too low. Inspect and adjust.
x	x	At pump	At pump	x	x	Plugged vacuum/pressure line. Inspect and repair.
x	x					Vanes sticking. Clean or replace.
x	x					Vanes worn. Replace.
x	x					Shaft seal worn. Replace.
x	x			x	x	Dust or offset powder in pump. Inspect and clean.
x	x			x		Motor not wired correctly. Check wiring diagram/line voltage.
		x	x	x	x	Running at too high an RPM. Check wiring diagram/line voltage.

For repair parts ordering information and exploded product view, visit our website or call us at the number listed below.

We have Gast Authorized Repair Facilities throughout the world. For the most up-to-date listing, contact one of our sales offices below:

Gast Manufacturing

P.O. Box 97
2300 M139 Highway
Benton Harbor, MI 49023-0097
Ph: 269-926-6171
Fax: 269-925-8288
www.gastmfg.com

Gast Group Limited

c/o IDEX Trading (Shanghai) Co., LTD
Room 3502-3505
No. 1027 Chang Ning Road,
Zhaofeng Plaza
Shanghai, China 200050
Phone +86-21-52415599
Fax +86-21-52418339

Gast Group Ltd.

Unit 11, The I O Centre
Nash Road
Redditch, B98 7AS
United Kingdom
Phone +44 (0)1527-504040
Fax +44 (0)1527-525262

GAST

A UNIT OF IDEX CORPORATION

www.gastmfg.com