



Models R3105-1, R3305A-1

Max. pressure – 43 inH₂O (60 Hz), 31 inH₂O (50 Hz)

Max. vacuum – 40 inH₂O (60 Hz), 28 inH₂O (50 Hz)

Max. air flow – 53 CFM (60 Hz), 44 CFM (50 Hz)

PRODUCT FEATURES

- Rugged construction, low maintenance
- Oilless operation
- UL and CSA approved TEFC motors with permanently sealed ball bearings
- Automatic restart thermal protection on single phase motors
- Aluminum blower housing, impeller, and cover
- Can be operated with no air flow through unit
- Can be mounted in any plane
- Inlet and outlet have internal muffling

RECOMMENDED ACCESSORIES

- Pressure gauge AJ496
- Inlet filter AJ126C (pressure)
- Vacuum gauge AJ497
- Inline filter AJ151C (vacuum)
- Muffler AJ121C
- Foam replacement kit K901

Product Dimensions (inches, mm)

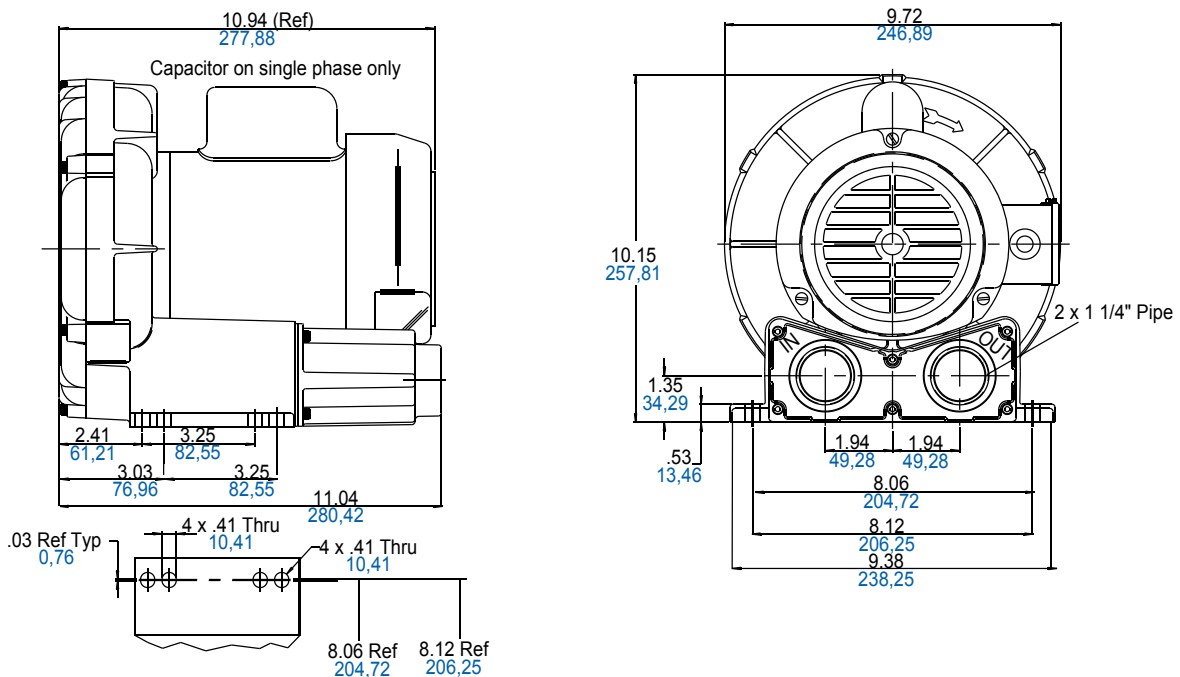

Product Specifications

MODEL NUMBER		R3105-1	R3305A-1
Motor Enclosure		TEFC	TEFC
HP/kW	60 Hz	.50/0,37	.50/0,37
	50 Hz	.33/0,25	.33/0,25
Voltage	60 Hz	115/208-230-1	208-230/460-3
	50 Hz	110/220-240-1	190-220/380-415-3
Amps	60 Hz	5.6/3.0-2.8	2.0-2.0/1.0
	50 Hz	5.2/2.6-3.1	1.6-1.8/.8-.84
Starting Amps	60 Hz	23.2 @ 115V	10.0 @ 230V
	50 Hz	23 @ 220V	7.9 @ 220V
Insulation Class		B	B
Recommended NEMA Starter Size		00/00	00/00
Net Weight (lbs/kg)		29/13,2	29/13,2

Product Performance

