

# LINEAR OILLESS COMPRESSORS

OPERATION & MAINTENANCE MANUAL | PART NO. SSP-13-1001 (REV.B)



Thank you for purchasing this Septic Sewage Pumps product. It is manufactured to the highest standards using quality materials. Please follow all recommended maintenance, operational and safety instructions and you will receive years of trouble-free service.

 <b>WARNING</b>	
	<b>PLEASE READ THIS MANUAL COMPLETELY BEFORE INSTALLING AND USING THIS MOTOR. SAVE THIS MANUAL FOR FUTURE REFERENCE AND KEEP IN THE VICINITY OF THE MOTOR.</b>

**Life** Depends upon speed, operating pressure and motor maintenance

## Product Use Criteria

- Pump only clean, dry air.
- Operate at 40°F - 104°F (4.4°C - 40°C)
- Protect unit from dirt and moisture.
- Do not pump flammable or explosive gases or use in an atmosphere that contains such gases.
- Corrosive gases and particulate material will damage unit. Water vapor, oil-based contaminants or other liquids must be filtered out.
- Oil-less compressors require NO lubrication
- Consult your Sepric Sewage Pumps Distributor/Representative before using at high altitudes.

# SEPTIC SEWAGE PUMPS.COM

A Division of Southwestern Controls 1-800-292-9087



**Your safety and the safety of others is extremely important.**

We have provided many important safety messages in this manual and on your product. Always read and obey all safety messages.



This is the safety alert symbol. This symbol alerts you to hazards that can kill or hurt you and others. The safety alert symbol and the words "DANGER" and "WARNING" will precede all safety messages. These words mean:

## **DANGER**

You **will** be killed or seriously injured if you don't follow instructions.

## **WARNING**

You **can** be killed or seriously injured if you don't follow instructions.

All safety messages will identify the hazard, tell you how to reduce the chance of injury, and tell you what can happen if the safety instructions are not followed.

## INSTALLATION

### **WARNING**



#### **Electrical Shock Hazard**

Disconnect electrical power at the circuit breaker or fuse box before installing this product.

Install this product where it will not come into contact with water or other liquids.

Install this product where it will be weather protected.

Electrically ground this product.

**Failure to follow these instructions can result in death, fire or electrical shock.**

**Correct installation is your responsibility.** Make sure you have the proper installation conditions and that installation clearances do not block air flow.

#### **Mounting**

This product must be installed on a flat, horizontal surface. Mounting the product to a stable, rigid operating surface and using shock mounts will reduce noise and vibration.

#### **Plumbing**

Remove plug from the OUT port. Connect with pipe and fittings that are the same size or larger than the product's port.

#### **Accessories**

Install relief valve and gauge at outlet to monitor performance. A check valve may be required to prevent back streaming through the compressor.

#### **Motor Control**

**It is your responsibility to contact a qualified electrician and assure that the electrical installation is adequate and in conformance with all national and local codes and ordinances.**

## ELECTRICAL CONNECTION

### **WARNING**



#### **Electrical Shock Hazard**

This product must be properly grounded.

Do not modify the plug provided. If it will not fit the outlet, have the proper outlet installed by a qualified electrician.

If repair or replacement of the cord or plug is necessary, do not connect the grounding wire to either flat blade terminal. The wire with insulation that is green with or without yellow stripes is the grounding wire.

Check the condition of the power supply wiring. Do not permanently connect this product to wiring that is not in good condition or is inadequate for the requirements of this product.

**Failure to follow these instructions can result in death, fire or electrical shock.**

In the event of an electrical short circuit, grounding reduces the risk of electric shock by providing an escape wire for the electric current. This product may be equipped with a power supply cord having a grounding wire with an appropriate grounding plug. The plug must be plugged into an outlet that is properly installed and grounded in accordance with all local codes and ordinances.

**Check with a qualified electrician or serviceman if the grounding instructions are not completely understood, or if you are not sure whether the product is properly grounded. Do not modify the plug provided. If it will not fit the outlet, have the proper outlet installed by a qualified electrician.**

## OPERATION

### Model that is permanently wired:

This product must be connected to a grounded, metallic, permanent wiring system, or an equipment grounding terminal or lead on the product.

Power supply wiring must conform to all required safety codes and be installed by a qualified person. Check that the supply voltage agrees with the voltage on the product nameplate.

### Model with a power supply cord:

This product must be grounded. For either 120-volt or 220/240-volt circuits connect the power supply cord grounding plug to a matching grounded outlet. Do not use an adapter. (See DIAGRAM A) Grasp plug to remove cord from outlet. Do not remove by pulling on the power cord.

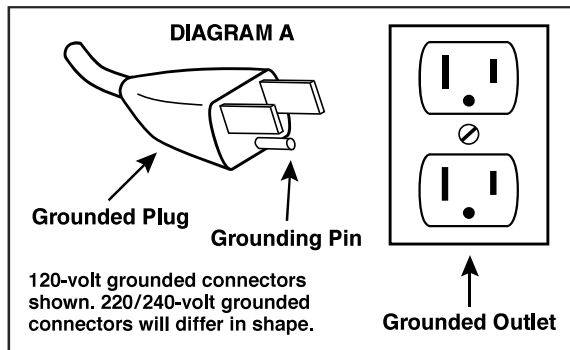

### Extension cords:

Use only a 3-wire extension cord that has a 3-blade grounding plug. Connect extension cord plug to a matching 3-slot receptacle. Do not use an adapter. Make sure your extension cord is in good condition. Check that the wire gage of the extension cord is the correct size wire to carry the current this product will draw. An undersized cord is a potential fire hazard, and will cause a drop in line voltage resulting in loss of power, causing the product to overheat. DIAGRAM B indicates the correct gage cord for length required and the ampere rating listed on the product nameplate.

**If in doubt, use the next heavier gage cord. The smaller the gage number, the heavier the wire gage.**

**DIAGRAM B**  
**Minimum Gage For Extension Cords**

Amps	Volts		Length of cord in feet											
	120v	240v	25	50	100	150	200	250	300	400	500	600	800	1000
0-2			18	18	18	16	16	14	14	12	12	10	10	8
2-3			18	18	16	14	14	12	12	10	10	8	8	8
3-4			18	18	16	14	12	12	10	10	8	8	8	8
4-5			18	18	14	12	12	10	10	8	8	8	8	8
5-6			18	16	14	12	10	10	8	8	8	8	8	8
6-8			18	16	12	10	10	8	6	6	6	6	6	6
8-10			18	14	12	10	8	8	6	6	6	6	6	6

## WARNING

### Injury Hazard

**Use only recommended air handling parts acceptable for pressure not less than 10 psi.**

**When provided, motor terminal covers must be in place for safe operation.**

**Product surfaces may become hot during operation, allow product surfaces to cool before handling.**

**Do NOT direct the air output towards your person. The air from the pump may contain solid or liquid that can result in eye or skin damage, wear proper eye protection.**

**Do NOT spray flammable or combustible liquid.**

**Do NOT block the air being discharged.**

**Pump must have sufficient room to allow for heat dissipation. Under extreme operating**

**temperature conditions, pump will automatically switch off until cool. DO NOT REMOVE PUMP CASING UNLESS AND UNTIL IT IS DISCONNECTED FROM THE ELECTRICAL SUPPLY.**

**Failure to follow these instructions can result in burns, eye injury or other serious injury.**

### Start Up

If pump fails to start or slows down significantly under load, shut off and disconnect from the power supply. Check that the voltage is correct for the pump.

### Safety switch system(only in DBMX and DBMS series)

When diaphragm is broken, the protrusion on top of the magnet frame will activate microswitch and shut down the power to prevent further damage.

### Alarm control system( optional )

The control is equipped with a three position toggle switch (DIAGRAM C). Operation in each switch position is as follows.

#### RUN:

During normal operation the switch is in the RUN or center position. The unit will function fully automated in the RUN mode. In the event of either of two pressure situation (low or high pressure) the controller will sound an alarm and light a visual indicator light to attract and advise the operator which of those conditions exist (low or high pressure).

#### MUTE:

The MUTE position will allow the unit to continue to run but will silence the audible alarm while leaving the visual alarm active.

#### TEST:

The TEST position will activate both the audible and visual alarms to check to see if they are functioning properly.

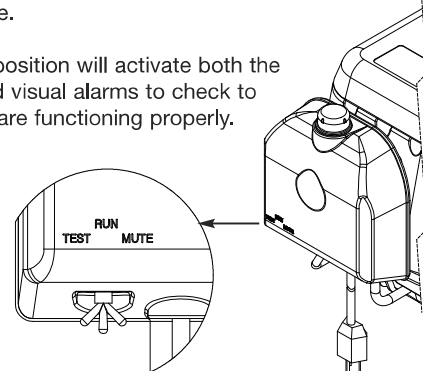
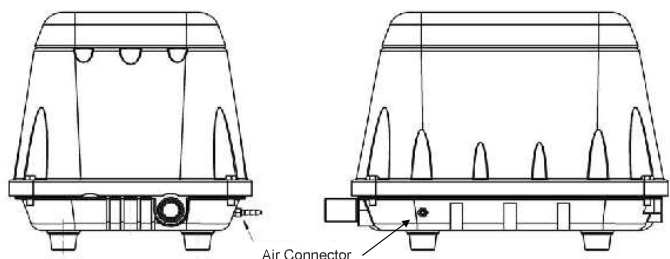

DIAGRAM C

Model: DB40-1250, DB60-1250, DB80-1250, DBM40-1250, DBM60-1250, DBM80-1250, DBMS60-1250, DBMS80-1250, DBMX80-1250, DBMX100-1250, DBMX120-1250, DBMX150-1250, DBMX200-1250, DBMX250-1250, DBMX300-1250.

These models must be connected with air pressure monitoring systems. The air connector is for air pressure monitoring systems only. Be sure to connect the air pump, through the air connector, with the air pressure monitoring system before operation.



## IMPORTANT SAFETY INSTRUCTIONS FOR AQUARIUM USE

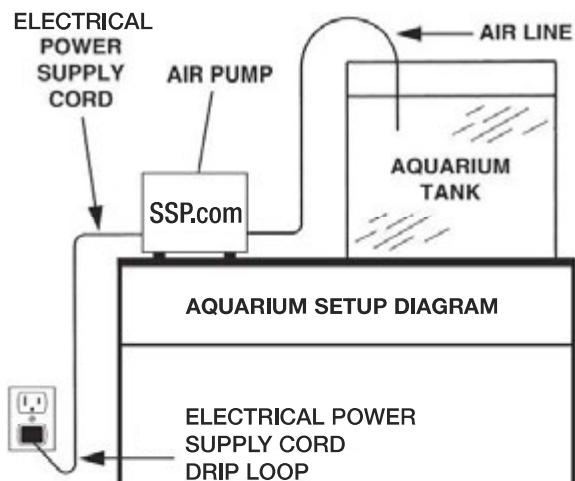

**WARNING –** Read and follow all safety instructions. To guard against injury, basic safety precautions should be observed.

**DANGER –** To avoid possible electrical shock, special care should be taken, since water is employed in the use of aquarium equipment. If the air pump, cord or plug are damaged in any way whatsoever, DO NOT attempt repairs by yourself, return the air pump to a Septic Sewage Pumps.com Authorized Service Facility for inspection and repair.

### Precautions for aquarium use:

1. If the air pump falls into the water, DO NOT reach into the water to retrieve it.
2. Carefully examine the appliance after installation. It should NOT be plugged into electrical power if there is water found on any part of the pump.
3. DO NOT operate any air pump if it has a damaged cord or plug, or if it is malfunctioning or has been dropped or damaged in any manner.
4. To avoid the possibility of the air pump plug or receptacle getting wet, position the aquarium stand and tank to one side of a wall-mounted receptacle to prevent water from dripping onto the receptacle or plug. A permanently fixed “drip loop” shown above in the AQUARIUM SETUP DIAGRAM, should be arranged by the user for each cord connecting an aquarium air pump to a receptacle. The “drip loop” is that part of the cord below the level of the receptacle, or the connector if an extension cord is used, which prevents water travelling along the cord from coming into contact with the receptacle.
5. If the plug or receptacle do get wet, DO NOT grasp the plug to disconnect the air pump. Instead disconnect the fuse or circuit breaker supplying power to the receptacle. Then unplug the air pump and examine for the presence of water on the plug or receptacle.

### Guidelines for aquarium use:

1. Close supervision is necessary when any air pump is used by or near children.
2. To avoid injury, DO NOT disassemble the air pump.
3. Always unplug an air pump from an outlet when not in use, before putting on or taking off parts and before cleaning. NEVER yank a cord to remove the plug from the receptacle. Grasp the plug and pull to disconnect.
4. DO NOT use an aquarium air pump for other than its intended use. The use of attachments which are not recommended or sold by SepticSewagePumps.com may cause an unsafe condition.
5. DO NOT install or store the air pump where it will be exposed to the weather or to temperatures below freezing.
6. Make sure an air pump mounted on a tank is securely installed before operating it.
7. Read and observe all the important notices on the air pump.

**SAVE THESE INSTRUCTIONS.**

**MAINTENANCE**

**! WARNING**



**Electrical Shock Hazard**

Disconnect electrical power supply cord before performing maintenance on this product.  
 If product is hard wired into system, disconnect electrical power at the circuit breaker or fuse box before performing maintenance on this product.  
 Failure to follow these instructions can result in death, fire or electrical shock.

**! WARNING**

**Injury Hazard**

Product surfaces may become hot during operation, allow product surfaces to cool before handling.  
**DONOT** direct air output from pump at your body.  
 Air stream from product may contain solid or liquid material that can result in eye or skin damage, wear proper eye protection.  
 Clean this product in a well ventilated area.  
 Failure to follow these instructions can result in burns, eye injury or other serious injury.

It is your responsibility to:

- Regularly inspect and make necessary repairs to product in order to maintain proper operation.
- Make sure that pressure is released from product before starting maintenance.
- NEVER add oil to this oil-less compressor.

Check intake filter after first 500 hours of operation. Clean filter and determine how frequently filter should be checked during future operation. **This one procedure will help to assure the product's performance and service life.**

**Cleaning**

**Do Not use kerosene or ANY other combustibile solvent to clean product.**

To clean the air filter (Recommended once every six months)

1. Loosen the screw on top (Refer to Diagram D and E).
2. Remove the filter cover.
3. Take the filter out and clean it with clean water and dry it.
4. Put it back and secure the filter cover with the Top Screw.

**Check that all external accessories such as relief valves and gauges are attached to cover and are not damaged before re-operating product.**

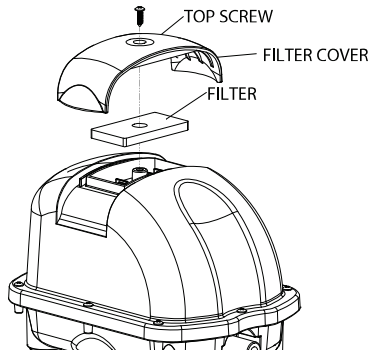

**DIAGRAM D**

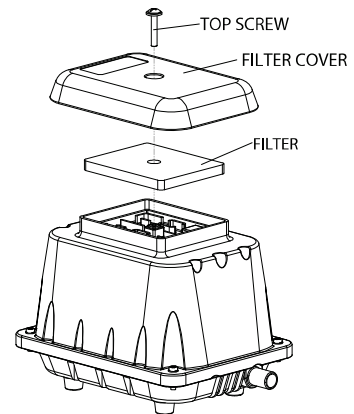

**DIAGRAM E**

**MAINTENANCE RECORD**

DATE	PROCEDURE PERFORMED



## SERVICE KIT INSTALLATION

### WARNING



#### Electrical Shock Hazard

**Disconnect electrical power supply cord before installing Service Kit.**

**If product is hard wired into system, disconnect electrical power at the circuit breaker or fuse box before installing Service Kit.**

**Disconnect air supply and vent all air lines to release pressure or vacuum.**

**Failure to follow these instructions can result in death, fire or electrical shock.**

Septic Sewage Pumps will NOT guarantee a field-rebuilt product.

For performance guarantee, the product must be returned to a [SepticSewagePumps.com](http://SepticSewagePumps.com) Authorized Service Facility. Service Kit contents vary with compressor models.

**If the compressor still does not produce proper pressure, send the unit to a [SepticSewagePumps.com](http://SepticSewagePumps.com) Authorized Service Facility for repair.**

### SERVICE KITS\*

model number	Diaphragm & Head Assembly Number		Filter number
	60Hz	50Hz	
DB40	DBD3040	N/A	DBF34680
DB40B	DBD3040	N/A	N/A
DB60	DBD6080	N/A	DBF34680
DB80	DBD6080	N/A	DBF34680
DBP40	DBD3040	N/A	DBPF40
DBM40	DBD3040	N/A	DBMF4680
DBM60	DBD6080	N/A	DBMF4680
DBM80	DBD6080	N/A	DBMF4680
DBMS60	N/A	N/A	DBMF4680
DBMS80	N/A	N/A	DBMF4680
DBMS60	DBD6080	N/A	DBMF4680
DBMS80	DBD6080	N/A	DBMF4680
DBMX80	DBMXD80100	N/A	DBMXF80100
DBMX100	DBMXD80100	N/A	DBMXF80100
DBMX120	DBMXD120	N/A	DBMXF80100
DBMX150	DBMXD150200	N/A	DBMXF150200
DBMX200	DBMXD150200	N/A	DBMXF150200
DBMX250	DBMXD250300	N/A	DBMXF250300
DBMX300	DBMXD250300	N/A	DBMXF250300
DT60	DTD6080	N/A	DTF6080
DT80	DTD6080	N/A	DTF6080

\* The service kit may contain parts for more than one model or style of linear pump. Parts not needed may be discarded. Kits listed are for stock models. For specific OEM models, please consult the factory. When corresponding or ordering kits, please give complete model and serial numbers.

# DB version series 40 、 60 、 80

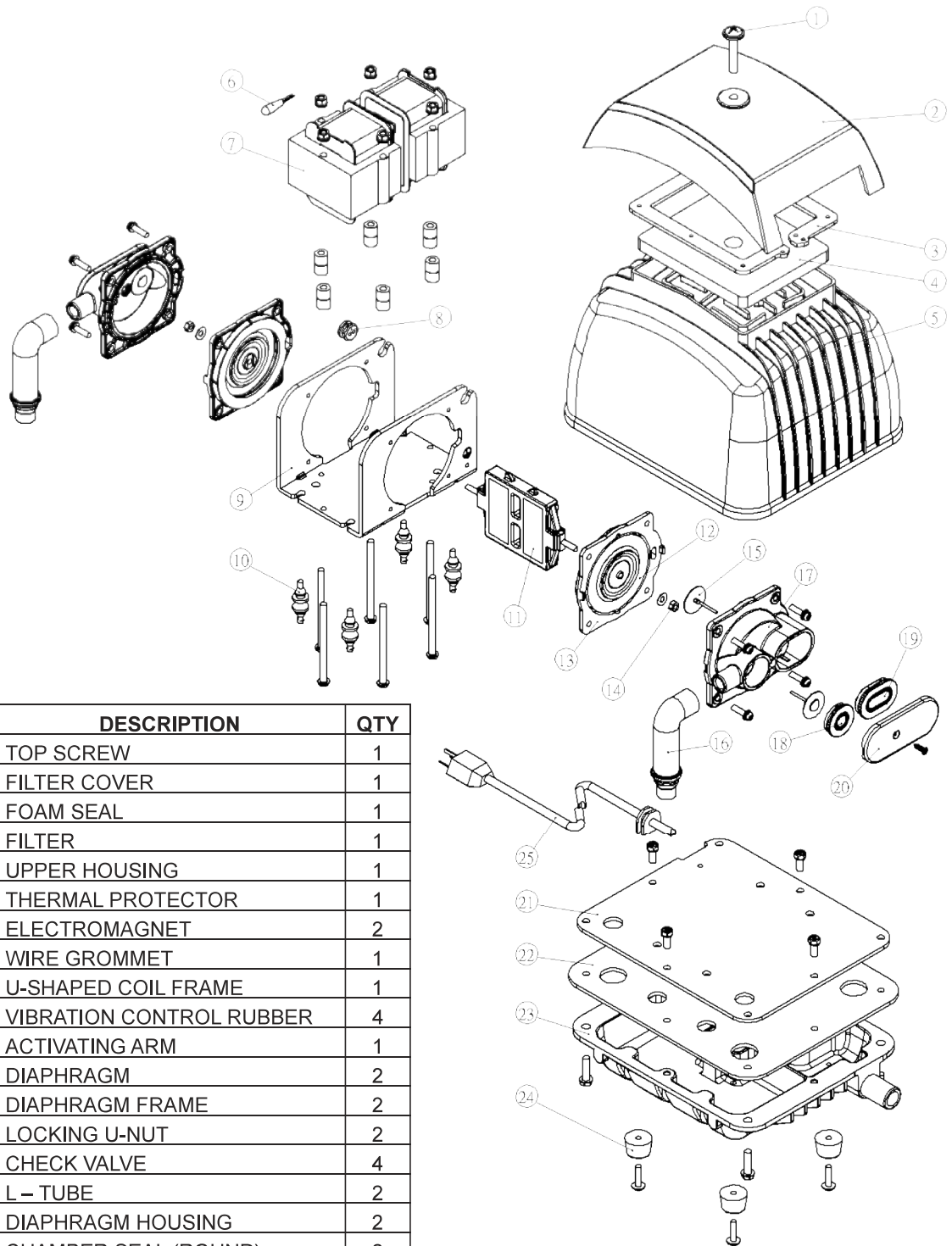

NO.	DESCRIPTION	QTY
1	TOP SCREW	1
2	FILTER COVER	1
3	FOAM SEAL	1
4	FILTER	1
5	UPPER HOUSING	1
6	THERMAL PROTECTOR	1
7	ELECTROMAGNET	2
8	WIRE GROMMET	1
9	U-SHAPED COIL FRAME	1
10	VIBRATION CONTROL RUBBER	4
11	ACTIVATING ARM	1
12	DIAPHRAGM	2
13	DIAPHRAGM FRAME	2
14	LOCKING U-NUT	2
15	CHECK VALVE	4
16	L - TUBE	2
17	DIAPHRAGM HOUSING	2
18	CHAMBER SEAL (ROUND)	2
19	CHAMBER SEAL (OVAL)	2
20	SIDE COVER (STEEL)	2
21	STEEL PLATE	1
22	GASKET	1
23	LOWER HOUSING	1
24	RUBBER FEET	4
25	POWER CORD	1

## DB version 40 、 60 、 80

### 1. To clean the air filter ( Recommended once every six months )

- A. Unscrew and remove the top screw then remove the filter cover.  
(As shown in Figure1)
- B. Take the filter out, clean it with clean water and dry it.
- C. Put the filter back and secure the filter cover by tightening the Top Screw.

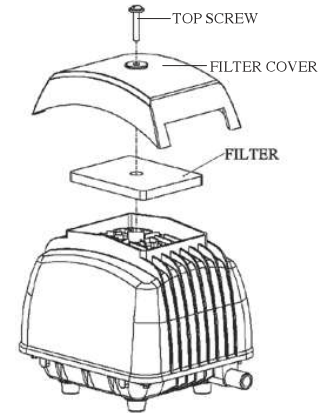

Figure 1

#### IMPORTANT:

- Make sure you have unplugged the power cord BEFORE opening.
- While making repairs, ALWAYS use two (2) Septic Sewage Pumps spacing plates, one on each side of the magnet to keep it stationary. Spacing plates are not provided with repair kits. Alternately you can use two rigid pieces of plastic 1" x 2" and approximately 1/16" (1.5MM) thick to stabilize the magnet between the coils.

### 2. To change the diaphragms

- A. Unscrew and remove the four housing screws around the aluminum upper housing, and take the upper housing off. (As shown in figure 2)
- B. Unscrew and remove the four diaphragm screws and remove the diaphragm housing. (As shown in figure 3)
- C. Unscrew and discard the locking u-nut from the center of the diaphragm.
- D. Remove and discard the used diaphragm.
- E. Install one new diaphragm by fitting the diaphragm's rubber studs into the available slot.
- F. Press the rim of the first diaphragm into the ring, hand tighten the locking u-nut, and then repeat steps B-F to install the second diaphragm. (placing one spacer between each side of the activating arm and a corresponding electromagnetic coil, may more easily allow the threaded rods on each end of the activating arm to align with the center hole in both diaphragms-Figure Not Available - see <http://youtu.be/t8npciP4M0M>)
- G. If not done already, place the spacers as described in item F. Secure one diaphragm by tightening a new locking u-nut (provided in repair kit) and then repeat with the second locking u-nut.
- H. Put the diaphragm housings back in place with the four diaphragm screws per side.
- I. IMPORTANT: REMEMBER TO REMOVE THE SPACERS ONCE THE DIAPHRAGM HOUSINGS HAVE BEEN REPLACED!
- J. Replace the upper housing by replacing and tightening the housing screws.

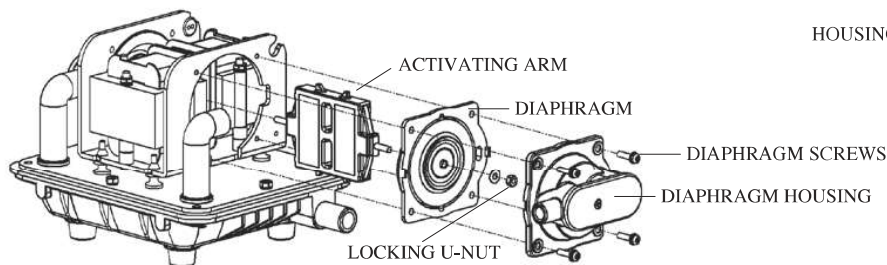

Figure 3

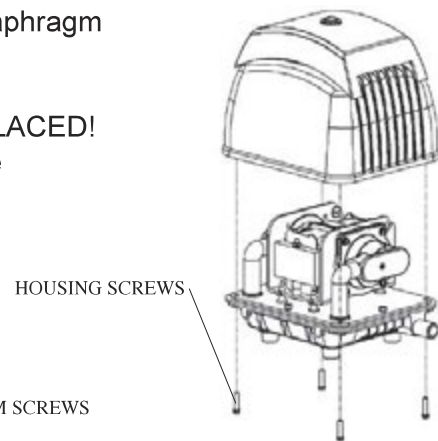
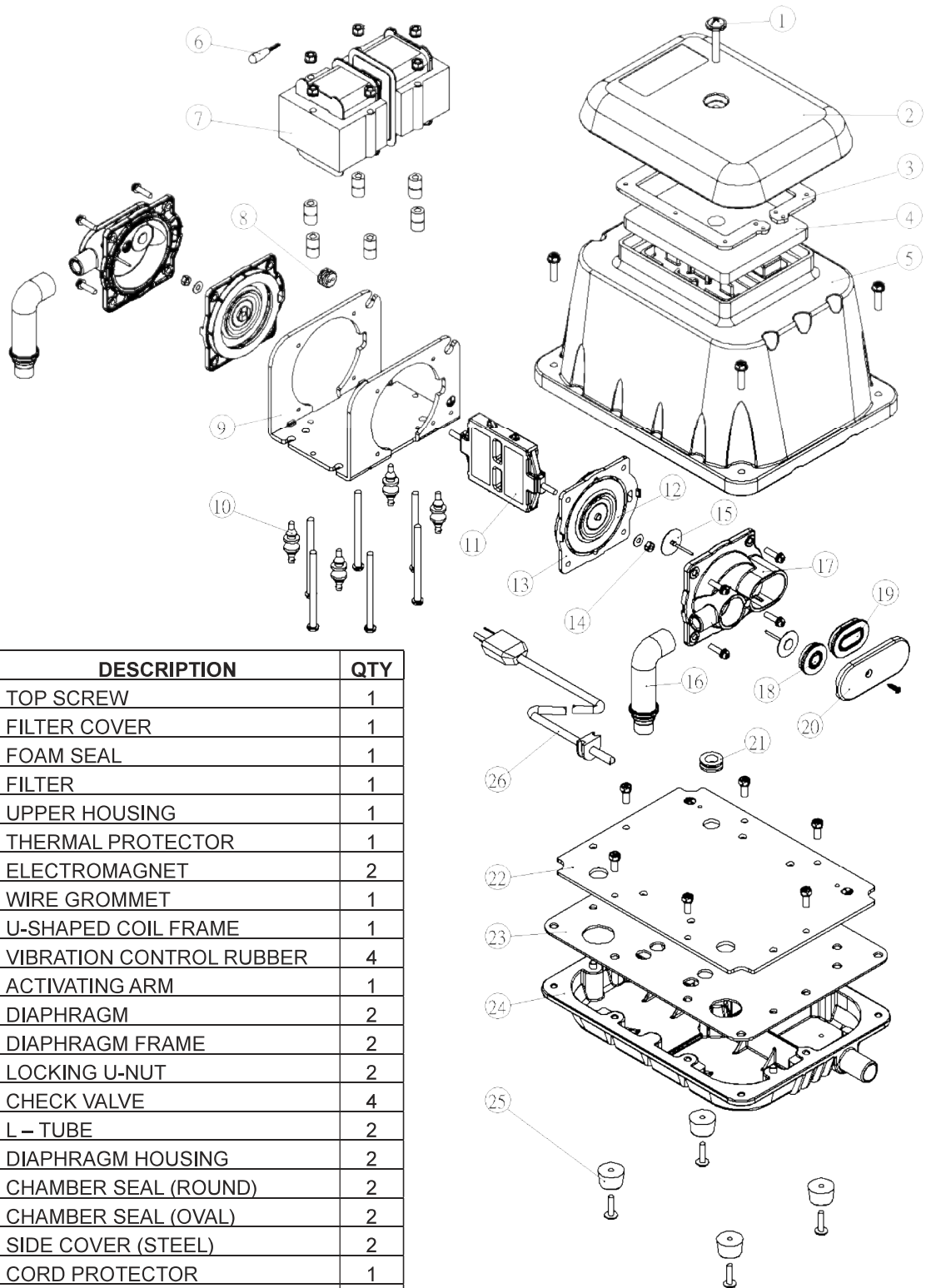

Figure 2



# DBM version series 40 、 60 、 80



NO.	DESCRIPTION	QTY
1	TOP SCREW	1
2	FILTER COVER	1
3	FOAM SEAL	1
4	FILTER	1
5	UPPER HOUSING	1
6	THERMAL PROTECTOR	1
7	ELECTROMAGNET	2
8	WIRE GROMMET	1
9	U-SHAPED COIL FRAME	1
10	VIBRATION CONTROL RUBBER	4
11	ACTIVATING ARM	1
12	DIAPHRAGM	2
13	DIAPHRAGM FRAME	2
14	LOCKING U-NUT	2
15	CHECK VALVE	4
16	L - TUBE	2
17	DIAPHRAGM HOUSING	2
18	CHAMBER SEAL (ROUND)	2
19	CHAMBER SEAL (OVAL)	2
20	SIDE COVER (STEEL)	2
21	CORD PROTECTOR	1
22	STEEL PLATE	1
23	GASKET	1
24	LOWER HOUSING	1
25	RUBBER FEET	4
26	POWER CORD	1

## DBM version 40 / 60 / 80

### 1. To clean the air filter ( Recommended once every six months )

- A. Unscrew and remove the Top Screw then remove the filter cover.  
(As shown in Figure1)
- B. Take the filter out, clean it with clean water and dry it.
- C. Put the filter back and secure the filter cover by tightening the Top Screw.

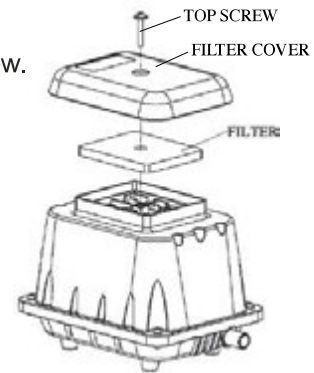

Figure 1

### IMPORTANT:

- Make sure you have unplugged the power cord BEFORE opening.
- While making repairs, ALWAYS use two (2) Septic Sewage Pumps spacing plates, one on each side of the magnet to keep it stationary. Spacing plates are not provided with repair kits. Alternately you can use two rigid pieces of plastic 1" x 2" and approximately 1/16" (1.5MM) thick to stabilize the magnet between the coils.

### 2. To change the diaphragms

- A. Unscrew and remove the eight housing screws around the aluminum upper housing, and take the upper housing off. (As shown in figure 2)
- B. Unscrew and remove the four diaphragm screws and remove the diaphragm housing. (As shown in figure 3)
- C. Unscrew and discard the locking u-nut from the center of the diaphragm.
- D. Remove and discard the used diaphragm.
- E. Install one new diaphragm by fitting the diaphragm's rubber studs into the available slot.
- F. Press the rim of the first diaphragm into the ring, hand tighten the locking u-nut, and then repeat steps B-F to install the second diaphragm. (placing one spacer between each side of the activating arm and a corresponding electromagnetic coil, may more easily allow the threaded rods on each end of the activating arm to align with the center hole in both diaphragms-Figure Not Available - see <http://youtu.be/t8npciP4M0M>)
- G. If not done already, place the spacers as described in item F. Secure one diaphragm by tightening a new locking u-nut (provided in repair kit) and then repeat with the second locking u-nut.
- H. Put the diaphragm housings back in place with the four diaphragm screws per diaphragm.
- I. IMPORTANT: REMEMBER TO REMOVE THE SPACERS ONCE THE DIAPHRAGM HOUSINGS HAVE BEEN REPLACED!
- J. Replace the upper housing by replacing and tightening the housing screws.

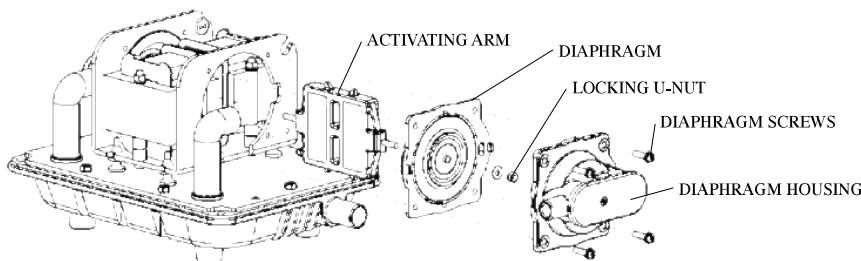

Figure 3

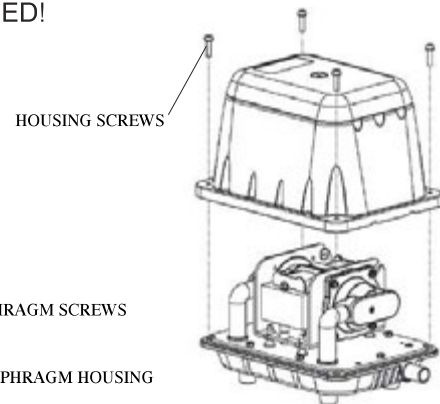
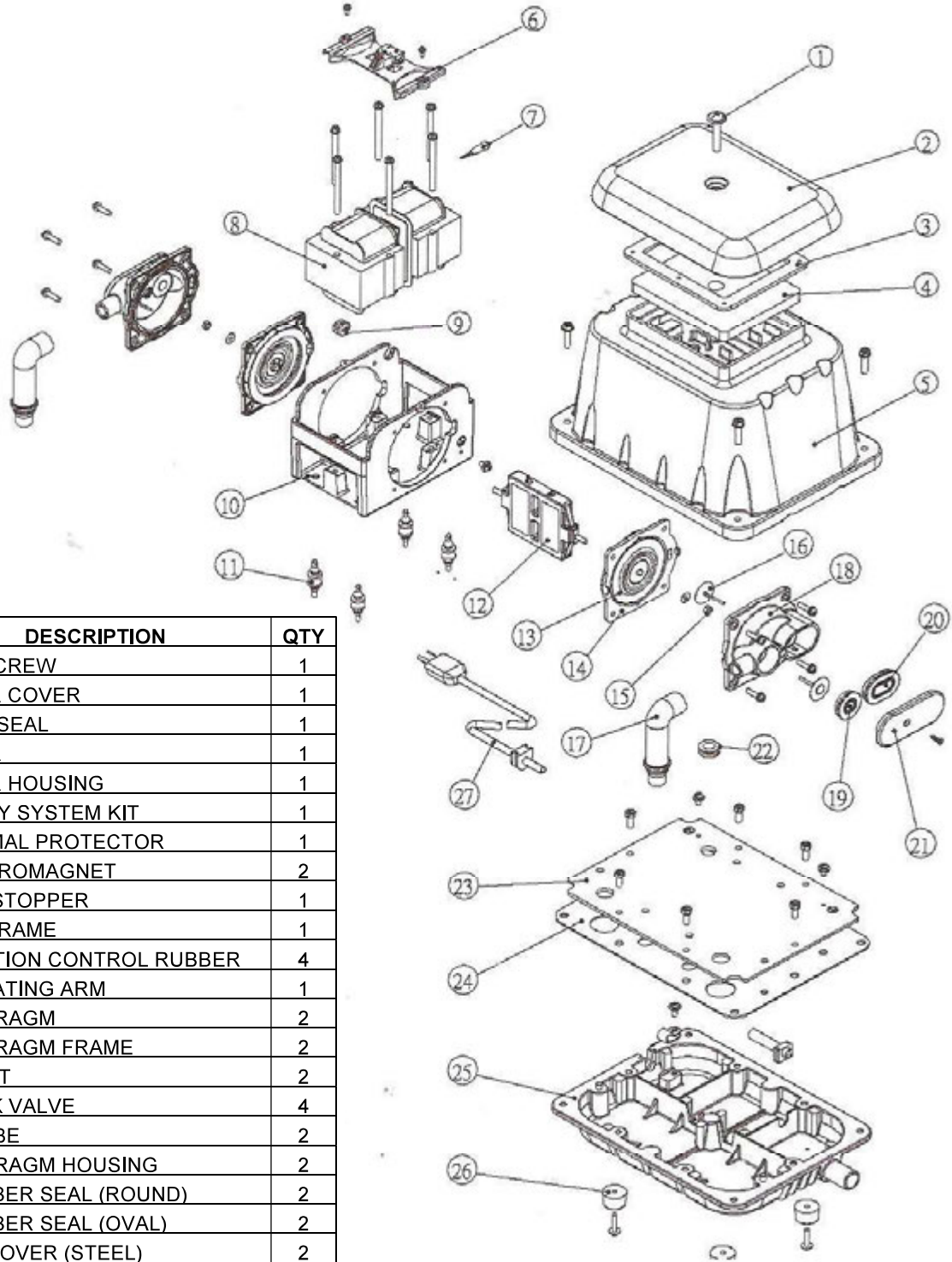

Figure 2

**(New Version)**  
**DBMS version series 60 - 80**



NO.	DESCRIPTION	QTY
1	TOP SCREW	1
2	FILTER COVER	1
3	FOAM SEAL	1
4	FILTER	1
5	UPPER HOUSING	1
6	SAFETY SYSTEM KIT	1
7	THERMAL PROTECTOR	1
8	ELECTROMAGNET	2
9	WIRE STOPPER	1
10	COIL FRAME	1
11	VIBRATION CONTROL RUBBER	4
12	ACTIVATING ARM	1
13	DIAPHRAGM	2
14	DIAPHRAGM FRAME	2
15	U - NUT	2
16	CHECK VALVE	4
17	L - TUBE	2
18	DIAPHRAGM HOUSING	2
19	CHAMBER SEAL (ROUND)	2
20	CHAMBER SEAL (OVAL)	2
21	SIDE COVER (STEEL)	2
22	CORD PROTECTOR	1
23	STEEL PLATE	1
24	GASKET	1
25	LOWER HOUSING	1
26	RUBBER FEET	4
27	POWER CORD	1

## DBMS version series 60 – 80

### 1. To clean the air filter ( Recommended once every six months )

- A. Unscrew and remove the Top Screw then remove the filter cover.  
(As shown in Figure1)
- B. Take the filter out, clean it with clean water and dry it.
- C. Put the filter back and secure the filter cover by tightening the Top Screw.

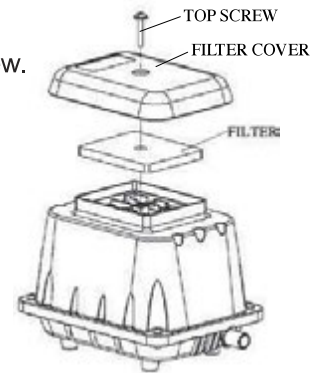

Figure 1

### IMPORTANT:

- **Make sure you have unplugged the power cord BEFORE opening.**
- While making repairs, ALWAYS use two (2) Septic Sewage Pumps spacing plates, one on each side of the magnet to keep it stationary. Spacing plates are not provided with repair kits. Alternately you can use two rigid pieces of plastic 1" x 2" and approximately 1/16" (1.5MM) thick to stabilize the magnet between the coils.

### 2. To change the diaphragms

- A. Unscrew and remove the eight housing screws around the aluminum upper housing, and take the upper housing off. (As shown in figure 2)
- B. Unscrew and remove the four diaphragm screws and remove the diaphragm housing. (As shown in figure 3)
- C. Unscrew and discard the locking u-nut from the center of the diaphragm.
- D. Remove and discard the used diaphragm.
- E. Install one new diaphragm by fitting the diaphragm's rubber studs into the available slot.
- F. Press the rim of the first diaphragm into the ring, hand tighten the locking u-nut, and then repeat steps B-F to install the second diaphragm. (placing one spacer between each side of the activating arm and a corresponding electromagnetic coil, may more easily allow the threaded rods on each end of the activating arm to align with the center hole in both diaphragms-Figure Not Available - see <http://youtu.be/t8npciP4M0M>)
- G. If not done already, place the spacers as described in item F. Secure one diaphragm by tightening a new locking u-nut (provided in repair kit) and then repeat with the second locking u-nut.
- H. Put the diaphragm housings back in place with the four diaphragm screws per diaphragm.
- I. **IMPORTANT: REMEMBER TO REMOVE THE SPACERS ONCE THE DIAPHRAGM HOUSINGS HAVE BEEN REPLACED!**
- J. Replace the upper housing by replacing and tightening the housing screws.

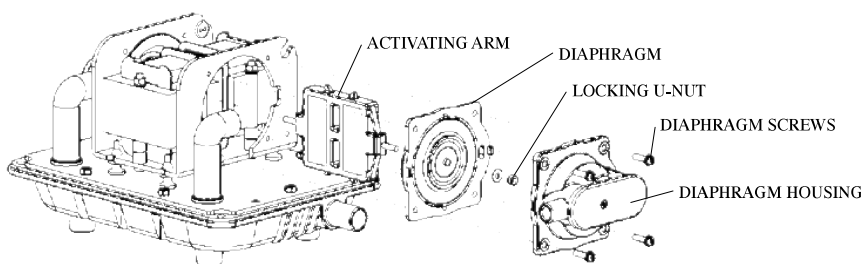

Figure 3

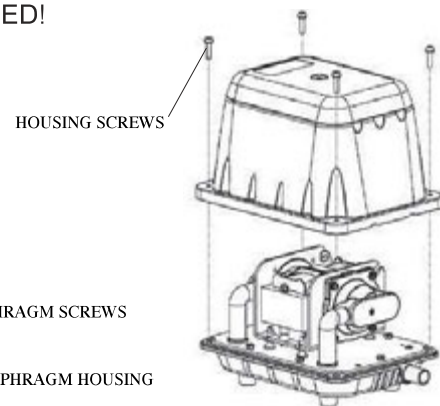
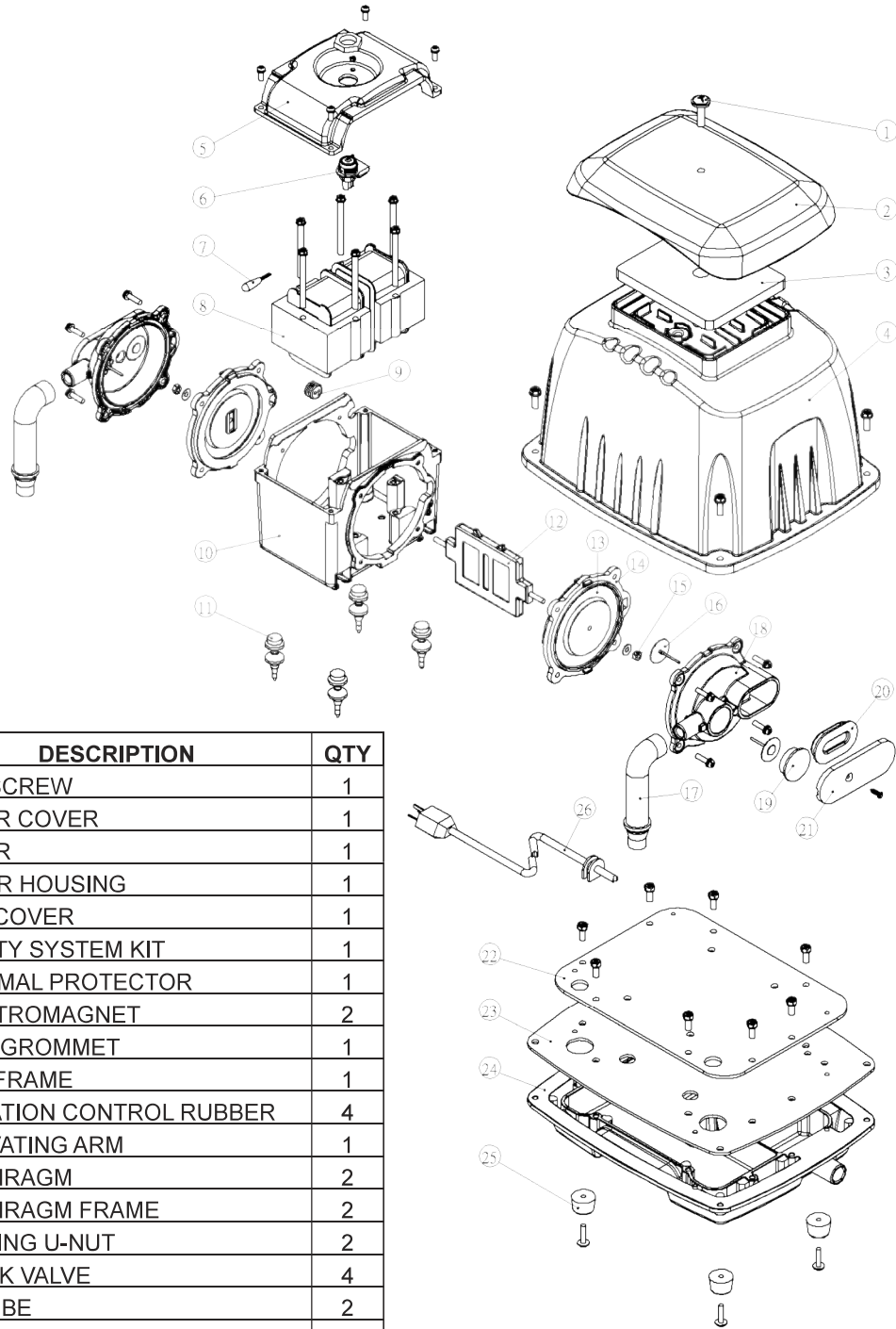

Figure 2

# DBMX version series 80 - 100



NO.	DESCRIPTION	QTY
1	TOP SCREW	1
2	FILTER COVER	1
3	FILTER	1
4	UPPER HOUSING	1
5	COIL COVER	1
6	SAFETY SYSTEM KIT	1
7	THERMAL PROTECTOR	1
8	ELECTROMAGNET	2
9	WIRE GROMMET	1
10	COIL FRAME	1
11	VIBRATION CONTROL RUBBER	4
12	ACTIVATING ARM	1
13	DIAPHRAGM	2
14	DIAPHRAGM FRAME	2
15	LOCKING U-NUT	2
16	CHECK VALVE	4
17	L - TUBE	2
18	DIAPHRAGM HOUSING	2
19	CHAMBER SEAL (ROUND)	2
20	CHAMBER SEAL (OVAL)	2
21	SIDE COVER (STEEL)	2
22	STEEL PLATE	1
23	GASKET	1
24	LOWER HOUSING	1
25	RUBBER FEET	4
26	POWER CORD	1



## DBMX version 80 / 100

### 1. To clean the air filter ( Recommended once every six months )

- A. Unscrew and remove the top screw then remove the filter cover.  
(As shown in Figure1)
- B. Take the filter out, clean it with clean water and dry it.
- C. Put the filter back and secure the filter cover by tightening the Top Screw.

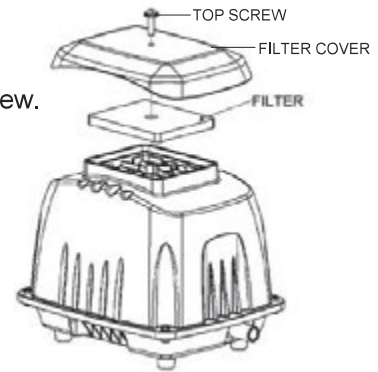

Figure 1

### IMPORTANT:

- Make sure you have unplugged the power cord BEFORE opening.
- While making repairs, ALWAYS use two (2) Septic Sewage Pumps spacing plates, one on each side of the magnet to keep it stationary. Spacing plates are not provided with repair kits. Alternately you can use two rigid pieces of plastic 1" x 2" and approximately 1/16" (1.5MM) thick to stabilize the magnet between the coils.

### CAUTION:

This model utilizes a powerful rare earth magnet. Upon disassembly of these parts, DO NOT allow the magnet to come into contact with any electrical devices. For example, wrist watches, cell phones, etc. could become dysfunctional upon contact with the magnet.

### 2. To change the diaphragms

- A. Unscrew and remove the four housing screws around the aluminum upper housing, and take the upper housing off. (As shown in figure 2)
- B. Unscrew and remove the four diaphragm screws and remove the diaphragm housing. (As shown in figure 3)
- C. Unscrew and discard the locking u-nut from the center of the diaphragm.
- D. Remove and discard the used diaphragm.
- E. Install one new diaphragm by fitting the diaphragm's rubber studs into the available slot.
- F. Press the rim of the first diaphragm into the ring, hand tighten the locking u-nut, and then repeat steps B-F to install the second diaphragm. (placing one spacer between each side of the activating arm and a corresponding electromagnetic coil, may more easily allow the threaded rods on each end of the activating arm to align with the center hole in both diaphragms-Figure Not Available - see <http://youtu.be/5d62itmGHgQ>)
- G. If not done already, place the spacers as described in item F. Secure one diaphragm by tightening a new locking u-nut (provided in repair kit) and then repeat with the second locking u-nut.
- H. Put the diaphragm housings back in place with the four diaphragm screws per diaphragm.
- I. IMPORTANT: REMEMBER TO REMOVE THE SPACERS ONCE THE DIAPHRAGM HOUSINGS HAVE BEEN REPLACED!
- J. Replace the coil cover and secure it firmly with the four cover screws.
- K. Replace the upper housing by replacing and tightening the four housing screws.

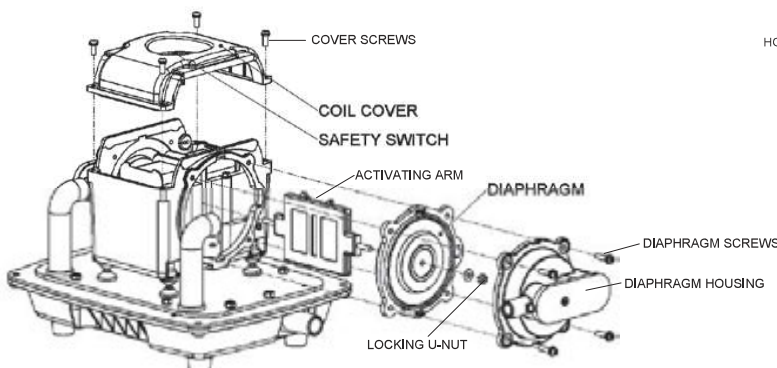

Figure 3

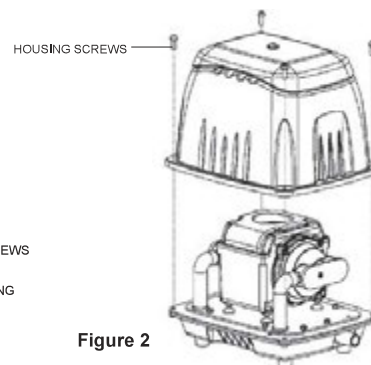
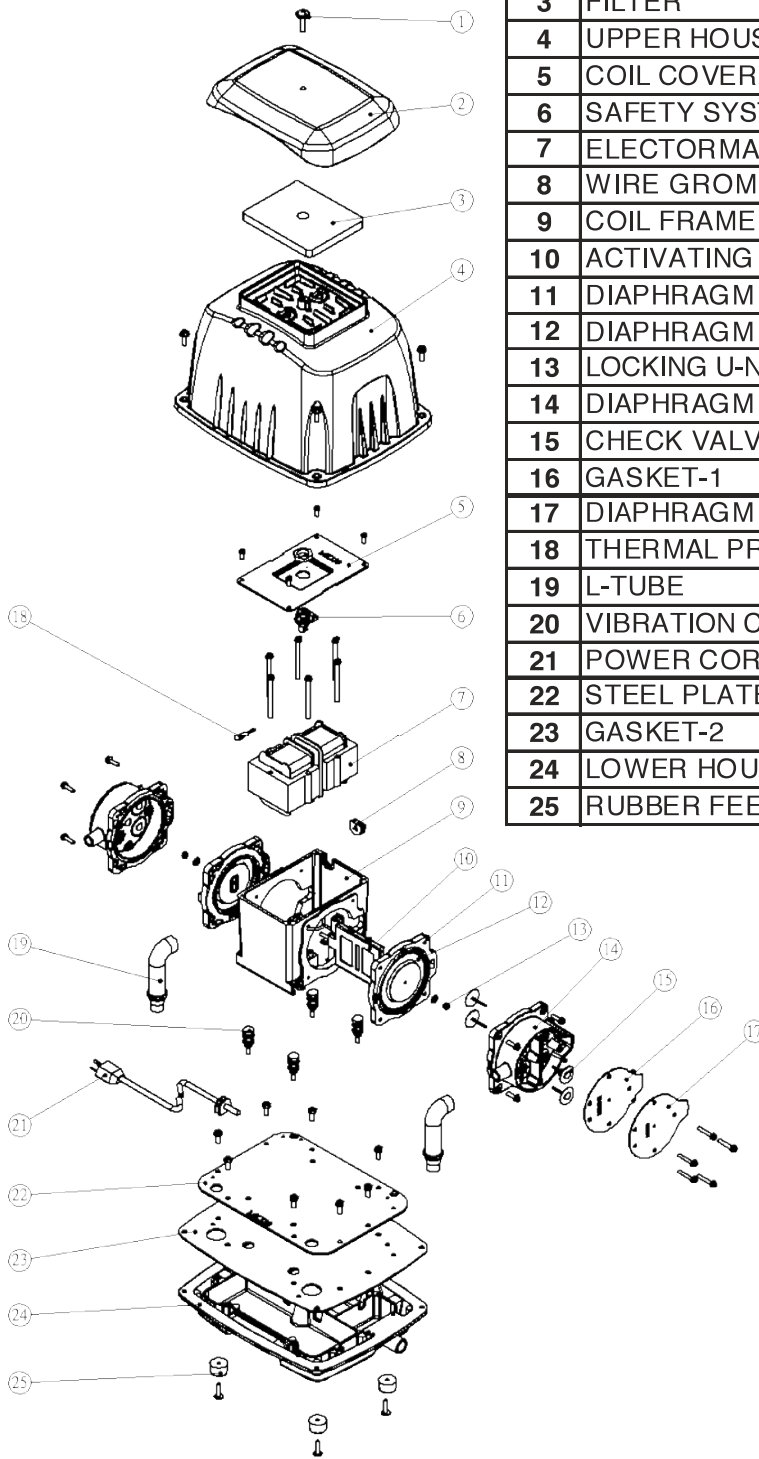

Figure 2

# DBMX version series 120

NO.	DESCRIPTION	QTY
1	TOP SCREW	1
2	FILTER COVER	1
3	FILTER	1
4	UPPER HOUSING	1
5	COIL COVER	1
6	SAFETY SYSTEM KIT	1
7	ELECTORMAGNET	2
8	WIRE GROMMET	1
9	COIL FRAME	1
10	ACTIVATING ARM	1
11	DIAPHRAGM FRAME	2
12	DIAPHRAGM	2
13	LOCKING U-NUT	2
14	DIAPHRAGM HOUSING	2
15	CHECK VALVE	8
16	GASKET-1	2
17	DIAPHRAGM HOUSING COVER	2
18	THERMAL PROTECTOR	1
19	L-TUBE	2
20	VIBRATION CONTROL RUBBER	4
21	POWER CORD	1
22	STEEL PLATE	1
23	GASKET-2	1
24	LOWER HOUSING	1
25	RUBBER FEET	4



## DBMX version 120

### 1. To clean the air filter ( Recommended once every six months )

- A. Unscrew and remove the Top Screw then remove the filter cover.  
(As shown in Figure1)
- B. Take the filter out, clean it with clean water and dry it.
- C. Put the filter back and secure the filter cover by tightening the Top Screw.

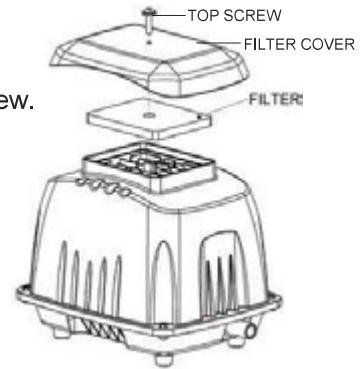

Figure 1

### IMPORTANT:

- Make sure you have unplugged the power cord BEFORE opening.
- While making repairs, ALWAYS use two (2) Septic Sewage Pumps spacing plates, one on each side of the magnet to keep it stationary. Spacing plates are not provided with repair kits. Alternately you can use two rigid pieces of plastic 1" x 2" and approximately 1/16" (1.5MM) thick to stabilize the magnet between the coils.

### CAUTION:

This model utilizes a powerful rare earth magnet. Upon disassembly of these parts, DO NOT allow the magnet to come into contact with any electrical devices. For example, wrist watches, cell phones, etc. could become dysfunctional upon contact with the magnet.

### 2. To change the diaphragms

- A. Unscrew and remove the four housing screws around the aluminum upper housing, and take the upper housing off. (As shown in figure 2)
- B. Unscrew and remove the four diaphragm screws and remove the diaphragm housing. (As shown in figure 3)
- C. Unscrew and discard the locking u-nut from the center of the diaphragm.
- D. Remove and discard the used diaphragm.
- E. Install one new diaphragm by fitting the diaphragm's rubber studs into the available slot.
- F. Press the rim of the first diaphragm into the ring, hand tighten the locking u-nut, and then repeat steps B-F to install the second diaphragm. (placing one spacer between each side of the activating arm and a corresponding electromagnetic coil, may more easily allow the threaded rods on each end of the activating arm to align with the center hole in both diaphragms-Figure Not Available - see <http://youtu.be/5d62itmGHgQ>)
- G. If not done already, place the spacers as described in item F. Secure one diaphragm by tightening a new locking u-nut (provided in repair kit) and then repeat with the second locking u-nut.
- H. Put the diaphragm housings back in place with the four diaphragm screws per diaphragm.
- I. IMPORTANT: REMEMBER TO REMOVE THE SPACERS  
ONCE THE DIAPHRAGM HOUSINGS HAVE BEEN REPLACED!
- J. Replace the coil cover and secure it firmly with the four cover screws.
- K. Replace the upper housing by replacing and tightening the four housing screws.

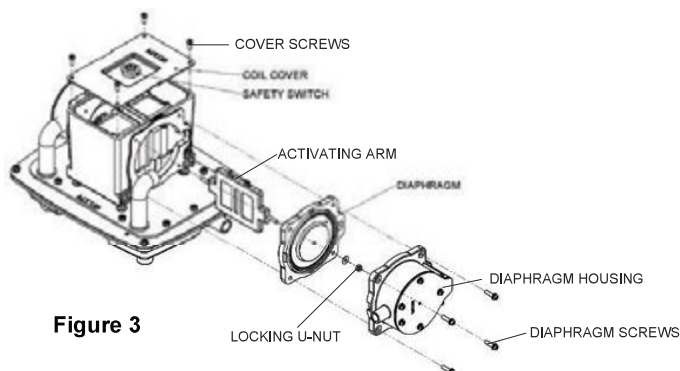

Figure 3

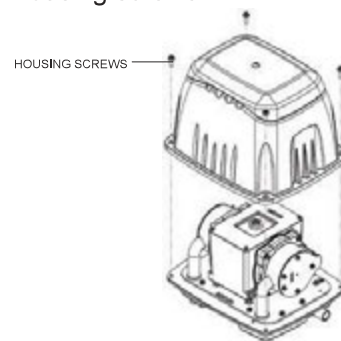
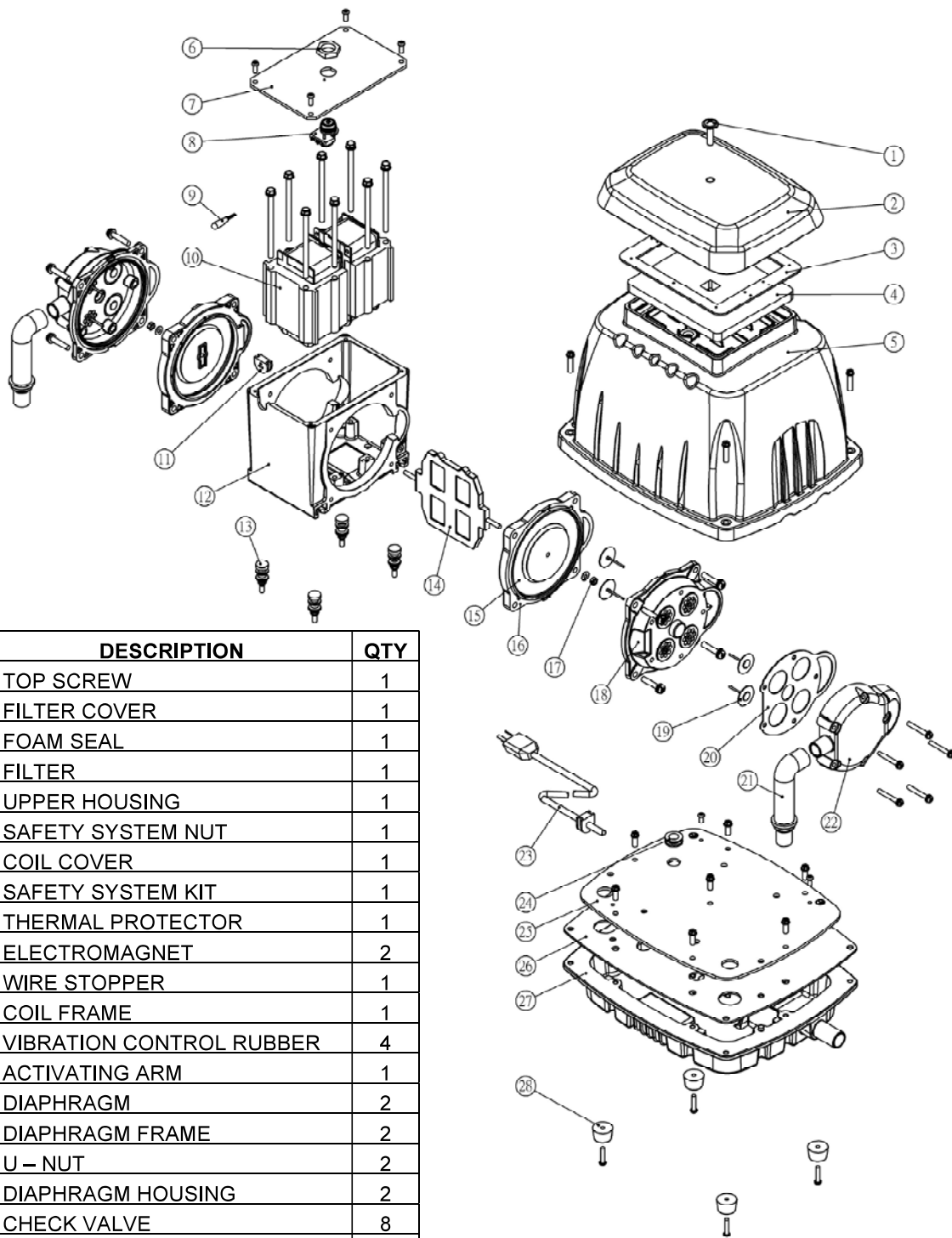

Figure 2

# DBMX version series 150 - 200



NO.	DESCRIPTION	QTY
1	TOP SCREW	1
2	FILTER COVER	1
3	FOAM SEAL	1
4	FILTER	1
5	UPPER HOUSING	1
6	SAFETY SYSTEM NUT	1
7	COIL COVER	1
8	SAFETY SYSTEM KIT	1
9	THERMAL PROTECTOR	1
10	ELECTROMAGNET	2
11	WIRE STOPPER	1
12	COIL FRAME	1
13	VIBRATION CONTROL RUBBER	4
14	ACTIVATING ARM	1
15	DIAPHRAGM	2
16	DIAPHRAGM FRAME	2
17	U - NUT	2
18	DIAPHRAGM HOUSING	2
19	CHECK VALVE	8
20	GASKET - 1	2
21	L - TUBE	2
22	DIAPHRAGM HOUSING COVER	2
23	POWER CORD	1
24	CORD PROTECTOR	1
25	STEEL PLATE	1
26	GASKET - 2	1
27	LOWER HOUSING	1
28	RUBBER FEET	4

## DBMX version 150 / 200

### 1. To clean the air filter ( Recommended once every six months )

- A. Unscrew and remove the Top Screw then remove the filter cover.  
(As shown in Figure1)
- B. Take the filter out, clean it with clean water and dry it.
- C. Put the filter back and secure the filter cover by tightening the Top Screw.

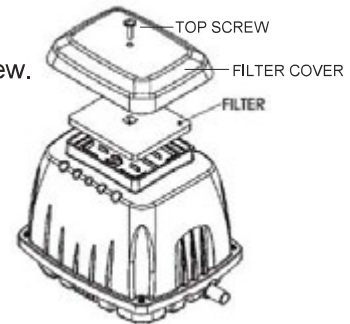

Figure 1

### IMPORTANT:

- Make sure you have unplugged the power cord BEFORE opening.
- While making repairs, ALWAYS use two (2) Septic Sewage Pumps spacing plates, one on each side of the magnet to keep it stationary. Spacing plates are not provided with repair kits. Alternately you can use two rigid pieces of plastic 1" x 2" and approximately 1/16" (1.5MM) thick to stabilize the magnet between the coils.

### CAUTION:

This model utilizes a powerful rare earth magnet. Upon disassembly of these parts, DO NOT allow the magnet to come into contact with any electrical devices. For example, wrist watches, cell phones, etc. could become dysfunctional upon contact with the magnet.

### 2. To change the diaphragms

- A. Unscrew and remove the four housing screws around the aluminum upper housing, and take the upper housing off. (As shown in figure 2)
- B. Unscrew and remove the four diaphragm screws and remove the diaphragm housing. (As shown in figure 3)
- C. Unscrew and discard the locking u-nut from the center of the diaphragm.
- D. Remove and discard the used diaphragm.
- E. Install one new diaphragm by fitting the diaphragm's rubber studs into the available slot.
- F. Press the rim of the first diaphragm into the ring, hand tighten the locking u-nut, and then repeat steps B-F to install the second diaphragm. (placing one spacer between each side of the activating arm and a corresponding electromagnetic coil, may more easily allow the threaded rods on each end of the activating arm to align with the center hole in both diaphragms-Figure Not Available - see <http://youtu.be/5d62itmGHgQ>)
- G. If not done already, place the spacers as described in item F. Secure one diaphragm by tightening a new locking u-nut (provided in repair kit) and then repeat with the second locking u-nut.
- H. Put the diaphragm housings back in place with the four diaphragm screws perdiaphragm.
- I. IMPORTANT: REMEMBER TO REMOVE THE SPACERS ONCE THE DIAPHRAGM HOUSINGS HAVE BEEN REPLACED!
- J. Replace the coil cover and secure it firmly with the four cover screws.
- K. Replace the upper housing by replacing and tightening the four housing screws.

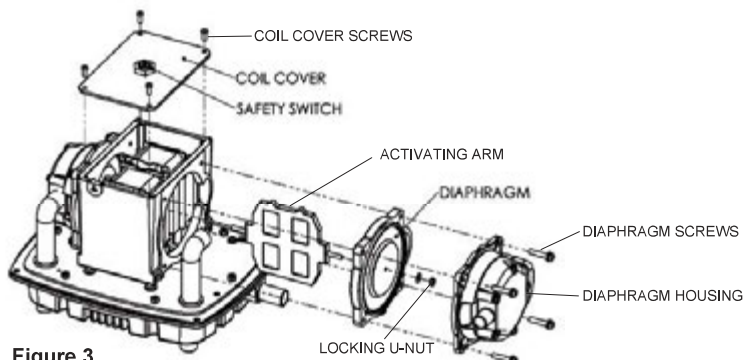

Figure 3

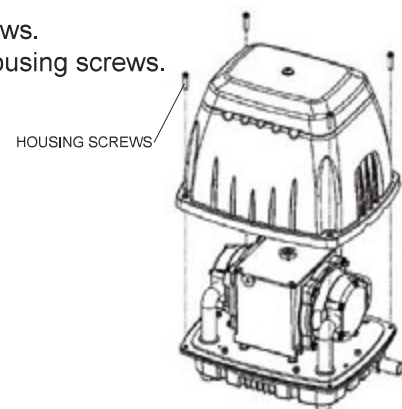
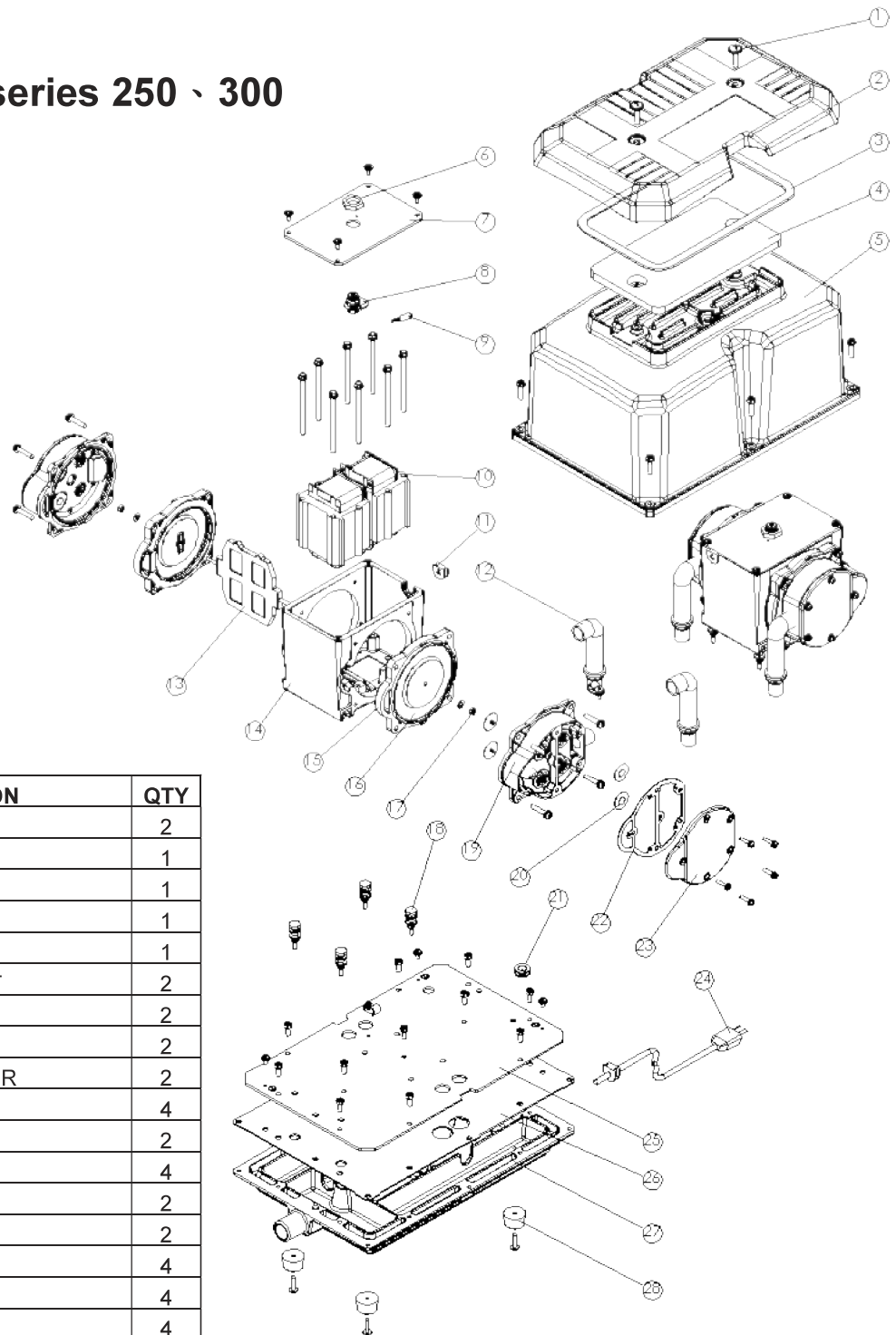

Figure 2



# DBMX version series 250 - 300



NO.	DESCRIPTION	QTY
1	TOP SCREW	2
2	FILTER COVER	1
3	FOAM SEAL	1
4	FILTER	1
5	UPPER HOUSING	1
6	SAFETY SYSTEM NUT	2
7	COIL COVER	2
8	SAFETY SYSTEM KIT	2
9	THERMAL PROTECTOR	2
10	ELECTROMAGNET	4
11	WIRE GROMMET	2
12	L-TUBE	4
13	ACTIVATING ARM	2
14	COIL FRAME	2
15	DIAPHRAGM FRAME	4
16	DIAPHRAGM	4
17	LOCKING U-NUT	4
18	VIBRATION CONTROL RUBBER	8
19	DIAPHRAGM HOUSING	4
20	CHECK VALVE	16
21	CORD PROTECTOR	1
22	GASKET - 1	4
23	DIAPHRAGM HOUSING COVER	4
24	POWER CORD	1
25	STEEL PLATE	1
26	GASKET - 2	1
27	LOWER HOUSING	1
28	RUBBER FEET	4

## DBMX version 250 / 300

### 1. To clean the air filter ( Recommended once every six months )

- A. Unscrew and remove the top screw then remove the filter cover.  
(As shown in Figure1)
- B. Take the filter out, clean it with clean water and dry it.
- C. Put the filter back and secure the filter cover by tightening the Top Screw.

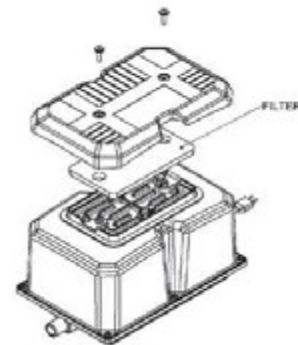

Figure 1

### IMPORTANT:

- Make sure you have unplugged the power cord BEFORE opening.
- While making repairs, ALWAYS use two (2) Septic Sewage Pumps spacing plates, one on each side of the magnet to keep it stationary. Spacing plates are not provided with repair kits. Alternately you can use two rigid pieces of plastic 1" x 2" and approximately 1/16" (1.5MM) thick to stabilize the magnet between the coils.

### CAUTION:

This model utilizes a powerful rare earth magnet. Upon disassembly of these parts, DO NOT allow the magnet to come into contact with any electrical devices. For example, wrist watches, cell phones, etc. could become dysfunctional upon contact with the magnet.

### 2. To change the diaphragms

- A. Unscrew and remove the six housing screws around the aluminum upper housing, and take the upper housing off. (As shown in figure 2)
- B. Unscrew and remove the four diaphragm screws and remove the diaphragm housing. (As shown in figure 3)
- C. Unscrew and discard the locking u-nut from the center of the diaphragm.
- D. Remove and discard the used diaphragm.
- E. Install one new diaphragm by fitting the diaphragm's rubber studs into the available slot.
- F. Press the rim of the first diaphragm into the ring, hand tighten the locking u-nut, and then repeat steps B-F to install the second diaphragm. (placing one spacer between each side of the activating arm and a corresponding electromagnetic coil, may more easily allow the threaded rods on each end of the activating arm to align with the center hole in both diaphragms-Figure Not Available - see <http://youtu.be/5d62itmGHgQ>)
- G. If not done already, place the spacers as described in item F. Secure one diaphragm by tightening a new locking u-nut (provided in repair kit) and then repeat with the second locking u-nut.
- H. Put the diaphragm housings back in place with the four diaphragm screws per diaphragm.
- I. IMPORTANT: REMEMBER TO REMOVE THE SPACERS ONCE THE DIAPHRAGM HOUSINGS HAVE BEEN REPLACED!
- J. Replace the coil cover and secure it firmly with the four cover screws.
- K. Replace the upper housing by replacing and tightening the four housing screws.

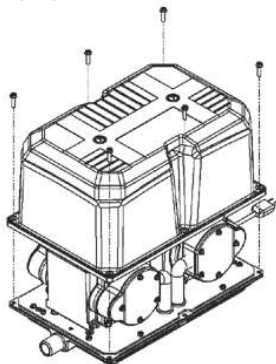

Figure 2

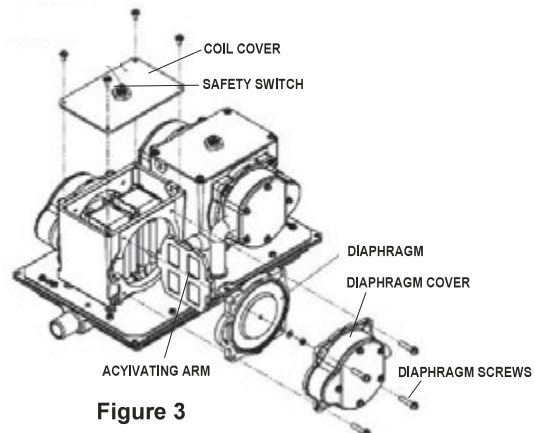
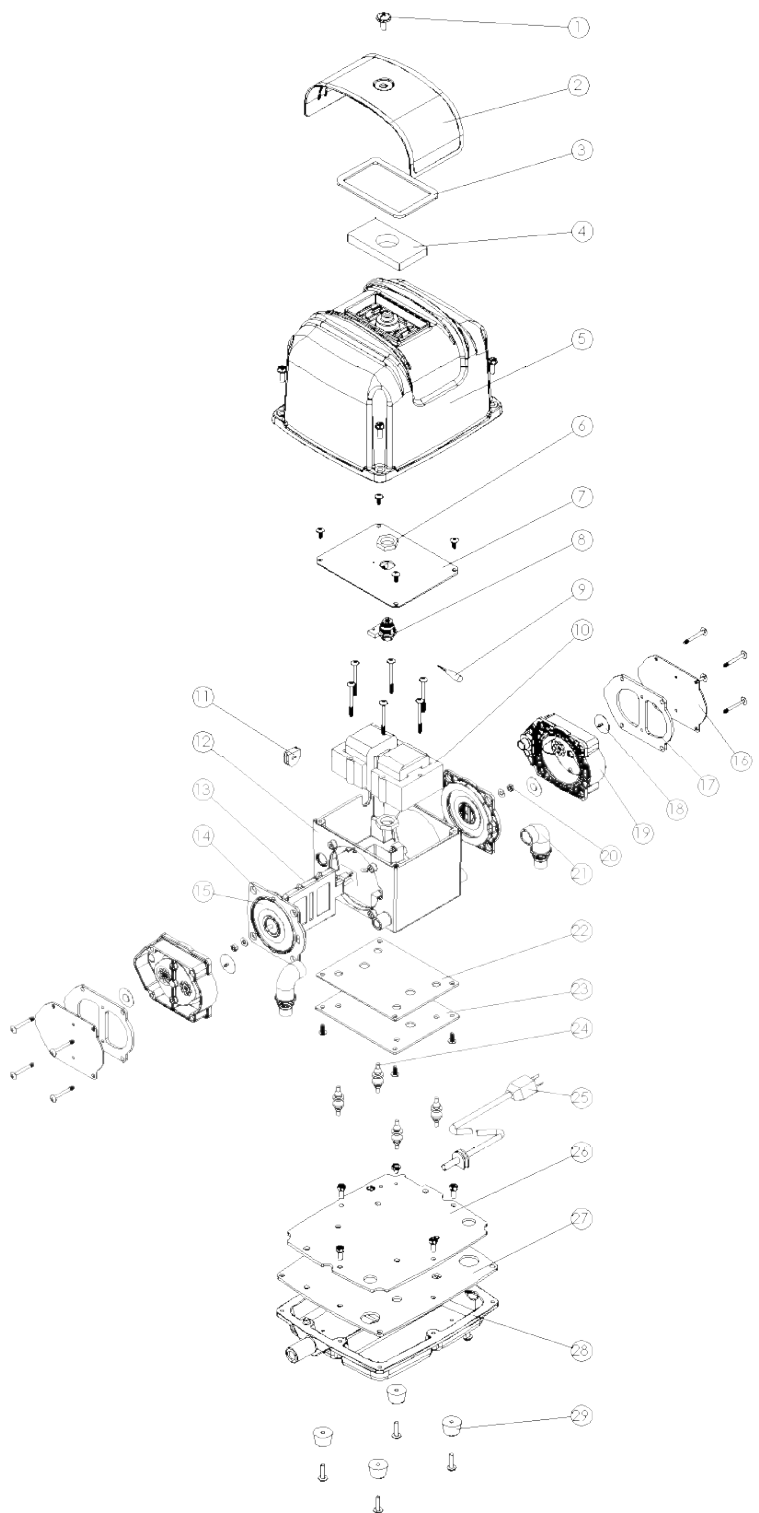

Figure 3

# DT version series 60 - 80

NO.	DESCRIPTION	QTY
1	TOP SCREW	1
2	FILTER COVER	1
3	FOAM SEAL	1
4	FILTER	1
5	UPPER HOUSING	1
6	SAFETY SYSTEM NUT	1
7	COIL COVER	1
8	SAFETY SYSTEM KIT	1
9	THERMAL PROTECTOR	1
10	ELECTROMAGNET	2
11	WIRE GROMMET	1
12	COIL FRAME	1
13	ACTIVATING ARM	1
14	DIAPHRAGM FRAME	2
15	DIAPHRAGM	2
16	DIAPHRAGM HOUSING COVER	2
17	GASKET - 1	2
18	CHECK VALVE	4
19	DIAPHRAGM HOUSING	2
20	LOCKING U-NUT	2
21	L-TUBE	2
22	GASKET - 2	1
23	STEEL PLATE - 1	1
24	VIBRATION CONTROL RUBBER	4
25	POWER CORD	1
26	STEEL PLATE - 2	1
27	GASKET - 3	1
28	LOWER HOUSING	1
29	RUBBER FEET	4



## DT version 60 / 80

### 1. To clean the air filter ( Recommended once every six months )

- Unscrew and remove the Top Screw then remove the filter cover.  
(As shown in Figure1)
- Take the filter out, clean it with clean water and dry it.
- Put the filter back and secure the filter cover by tightening the Top Screw.

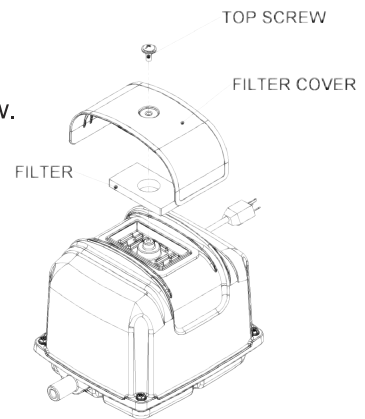

Figure 1

### IMPORTANT:

- **Make sure you have unplugged the power cord BEFORE opening.**
- **While making repairs, ALWAYS use two (2) Septic Sewage Pumps spacing plates, one on each side of the magnet to keep it stationary. Spacing plates are not provided with repair kits. Alternately you can use two rigid pieces of plastic 1" x 2" and approximately 1/16" (1.5MM) thick to stabilize the magnet between the coils.**

### CAUTION:

This model utilizes a powerful rare earth magnet. Upon disassembly of these parts, DO NOT allow the magnet to come into contact with any electrical devices. For example, wrist watches, cell phones, etc. could become dysfunctional upon contact with the magnet.

### 2. To change the diaphragms

- Unscrew and remove the four housing screws around the aluminum upper housing, and take the upper housing off. (As shown in figure 2)
- Unscrew and remove the four diaphragm screws and remove the diaphragm housing. (As shown in figure 3)
- Unscrew and discard the locking u-nut from the center of the diaphragm.
- Remove and discard the used diaphragm.
- Install one new diaphragm by fitting the diaphragm's rubber studs into the available slot.
- Press the rim of the first diaphragm into the ring, hand tighten the locking u-nut, and then repeat steps B-F to install the second diaphragm. (placing one spacer between each side of the activating arm and a corresponding electromagnetic coil, may more easily allow the threaded rods on each end of the activating arm to align with the center hole in both diaphragms-Figure Not Available - see <http://youtu.be/5d62itmGHgQ>)
- If not done already, place the spacers as described in item F. Secure one diaphragm by tightening a new locking u-nut (provided in repair kit) and then repeat with the second locking u-nut.
- Put the diaphragm housings back in place with the four diaphragm screws per diaphragm.
- IMPORTANT: REMEMBER TO REMOVE THE SPACERS ONCE THE DIAPHRAGM HOUSINGS HAVE BEEN REPLACED!**
- Replace the coil cover and secure it firmly with the four cover screws.
- Replace the upper housing by replacing and tightening the four housing screws.

HOUSING SCREWS

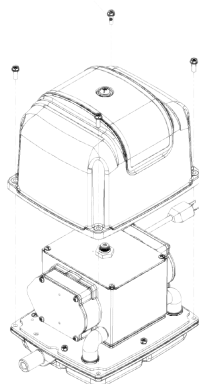

Figure 2

SAFETY SWITCH  
COIL COVER SCREWS  
COIL COVER

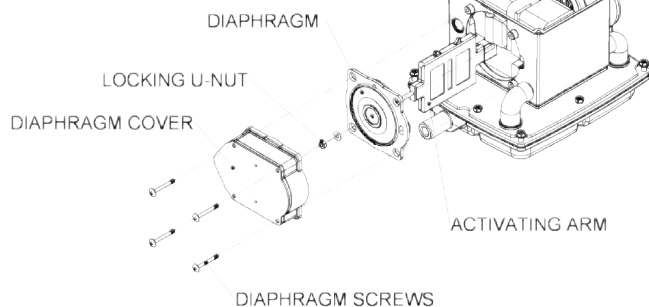

Figure 3

## TROUBLESHOOTING CHART

Low Pressure	High Pressure	Pump Overheat	Motor Overload	Excess Noise	Reason and remedy for problem.
•					Filter dirty. Clean or replace.
•					Valves dirty or valves bent. Clean or replace.
•		•	•		Worn or torn diaphragm. Repair or replace.
	•				Relief valve set too high. Inspect and adjust.
•					Relief valve set too low. Inspect and adjust.
	•				Plugged pressure line. Inspect and repair.
•					Low voltage, won't start. Check power source.
	•	•	•	•	Voltage wrong. Check power source.
		•		•	Rod magnet misalignment. Realign.
•					Leaky hose or check valve. Replace.
•		•	•	•	Dirt or liquid in compressor. Inspect and clean.
•				•	Blown or leaking head gasket or tubes. Replace.



## WARRANTY

SEPTIC SEWAGE PUMPS finished products, when properly installed and operated under normal conditions of use, are warranted by SEPTIC SEWAGE PUMPS to be free from defects in material and workmanship for a period of twelve months (12) months from the date of purchase from SEPTIC SEWAGE PUMPS or an authorized SEPTIC SEWAGE PUMPS Representative or Distributor. In order to obtain performance under this warranty, the buyer must promptly (in no event later than thirty (30) days after discovery of the defect) give written notice of the defect to an authorized Service Center. Buyer is responsible for freight charges both to and from SEPTIC SEWAGE PUMPS in all cases.

This warranty does not apply to electric motors, electrical controls, and gasoline engines not supplied by SEPTIC SEWAGE PUMPS. SEPTIC SEWAGE PUMPS' warranties also do not extend to any goods or parts which have been subjected to misuse, lack of maintenance, neglect, damage by accident or transit damage.

THIS EXPRESS WARRANTY EXCLUDES ALL OTHER WARRANTIES OR REPRESENTATIONS EXPRESSED OR IMPLIED BY ANY LITERATURE, DATA, OR PERSON. SEPTIC SEWAGE PUMPS' MAXIMUM LIABILITY UNDER THIS EXCLUSIVE REMEDY SHALL NEVER EXCEED THE COST OF THE SUBJECT PRODUCT AND SEPTIC SEWAGE PUMPS RESERVES THE RIGHT, AT ITS SOLE DISCRETION, TO REFUND THE PURCHASE PRICE IN LIU OF REPAIR OR REPLACEMENT.

SEPTIC SEWAGE PUMPS WILL NOT BE RESPONSIBLE OR LIABLE FOR INDIRECT OR CONSEQUENTIAL DAMAGES OF ANY KIND, however arising, including but not limited to those for use of any products, loss of time, inconvenience, lost profit, labor charges, or other incidental or consequential damages with respect to persons, business, or property, whether as a result of breach of warranty, negligence or otherwise. Notwithstanding any other provision of this warranty, BUYER'S REMEDY AGAINST SEPTIC SEWAGE PUMPS FOR GOODS SUPPLIED OR FOR NON-DELIVERED GOODS OR FAILURE TO FURNISH GOODS, WHETHER OR NOT BASED ON NEGLIGENCE, STRICT LIABILITY OR BREACH OF EXPRESS OR IMPLIED WARRANTY, IS LIMITED SOLELY, AT SEPTIC SEWAGE PUMPS' OPTION, TO REPLACEMENT OF OR CURE OF SUCH NONCONFORMING OR NON-DELIVERED GOODS OR RETURN OF THE PURCHASE PRICE FOR SUCH GOODS AND IN NO EVENT SHALL EXCEED THE PRICE OR CHARGE FOR SUCH GOODS. SEPTIC SEWAGE PUMPS EXPRESSLY DISCLAIMS ANY WARRANTY OF MERCHANTABILITY OR FITNESS FOR A PARTICULAR USE OR PURPOSE WITH RESPECT TO THE GOODS SOLD. THERE ARE NOT WARRANTIES WHICH EXTEND BEYOND THE DESCRIPTIONS SET FORTH IN THIS WARRANTY, notwithstanding any knowledge of SEPTIC SEWAGE PUMPS regarding the use or uses intended to be made of goods, proposed changes or additions to goods, or any assistance or suggestions that may have been made by SEPTIC SEWAGE PUMPS personnel.

Authorized extensions of warranties by the customer shall remain the customer's responsibility.

CUSTOMER IS RESPONSIBLE FOR DETERMINING THE SUITABILITY OF SEPTIC SEWAGE PUMPS PRODUCTS FOR CUSTOMER'S USE OR RESALE, OR FOR INCORPORATING THEM INTO OBJECTS OR APPLICATIONS WHICH CUSTOMER DESIGNS, ASSEMBLES, CONSTRUCTS OR MANUFACTURES.

This warranty can be modified only by SEPTIC SEWAGE PUMPS' senior management by signing a specific written description of any modifications.

*SPECIAL NOTE: Should the part that needs to be returned for warranty be a part that was inside any part of your septic tank, after receiving Return Authorization, it SHALL be returned to Septic Sewage Pumps or the Manufacturer inside a plastic sealed bag. This is for the safety of both the warranty process people who work at Septic Sewage Pumps or Manufacturer and the UPS/Mail people who are handling the product during shipping. If for any reason the warranty product that has been in contact with your sewage system is sent to us without the safety of being inside a sealed plastic bag your warranty will not be processed.*

**Contact Septic Sewage Pumps between the hours of 8:00 am to 4:00 pm Central Standard Time to receive Return Authorization. To receive Warranty Authorization you will need to provide Septic Sewage Pumps with proof of the original purchase. Please contact Septic Sewage Pumps prior to returning any merchandise for warranty consideration.**

**SEPTIC SEWAGE PUMPS.COM**

*A Division of Southwestern Controls*

8808 Sovereign Row, Dallas, Texas 75247 • Phone: 1-800-292-9087

**SEPTIC SEWAGE PUMPS.COM**

**A Division of Southwestern Controls 1-800-292-9087**

